

# LUMIMAX<sup>®</sup>



## KNOWLEDGE BASE

V042025



## USEFUL FACTS ABOUT MACHINE VISION LIGHTING SYSTEMS

made by **iim** MEASUREMENT ENGINEERING in Germany



# Preface

## Dear Reader,

Thank you for your interest in our Knowledge Base on the topic of LED lighting technology in industrial Machine Vision. The idea behind the LUMIMAX<sup>®</sup> Knowledge Base is to give you some background knowledge of LED lighting technology, to simplify your choice of the right lighting and to inform you about the kinds of applications for which our LUMIMAX<sup>®</sup> LED lighting can be used.

While the human eye can adapt itself to a wide range of environments and situations, the camera only sees what is actually made visible to it by the lighting conditions. Accordingly, image quality is entirely dependent on the right choice of lighting. The material, surface and colour of the test objects are just some of the challenges that need to be met by selecting the optimal lighting system. Other factors include difficult ambient conditions, such as extraneous light or motion blur. Achieving the right kind of lighting not only saves time and money in image analysis, but is also the key to mastering your Machine Vision tasks.

Please feel free to contact us if you have any questions about our product range.  
First of all, however, we wish you a pleasant read of our Knowledge Base!



Your LUMIMAX<sup>®</sup> Knowledge Base Team



## A brief introduction to iiM GmbH

iiM GmbH – part of Union Park's holding company Exaktera – is developer, manufacturer and distributor of high-quality, high-performance products for industrial image processing.

Based in Suhl, Germany, we develop and manufacture high-performance and highly functional LED illumination under the LUMIMAX® brand for Machine Vision applications in a very wide range of industrial sectors, including automotive, semiconductor, pharma, and the food and beverage industry.

A further department develops and markets special measuring technology and peripherals for the cable and wire industry to record geometric features, particularly on insulating covers and cable sheathing, in accordance with standards.

A team of over 80 engineers, technicians and skilled workers assists our customers as a partner when realising their challenges.

Certified in accordance with Global Certificate ISO 9001:2015 by DEKRA, iiM GmbH guarantees quality at the highest level.

## LUMIMAX® LED Lighting

### Quality

Made in Germany – we are committed to the very highest levels of quality and functionality, guarantee firstclass service and work together with regional partners. All development and manufacturing work is completed at our head office in Suhl. This means our customers benefit from rapid order processing and short lead times.

To ensure a universally high standard for all our processes, the iiM GmbH quality management system is audited annually to the ISO 9001:2015 standard by DEKRA Certification GmbH.

### Technology

High-performance lighting products with integrated controller technology for continuous, switch or strobe operation guarantee a maximum level of functionality while providing stable lighting for your test objects, independent of extraneous light – and even for extremely fast-moving processes.

Functional accessories and well-designed connection solutions reduce the integration time for your Machine Vision application.



























### Experience

Thanks to our company's long history in industrial Machine Vision, we can apply a huge wealth of experience and expertise to product design and manufacturing, and to customer consulting work.

We see our customers as equal partners. Which is why we work from a basis of continuous and close cooperation.



## Table of contents

<b>1. Influence of the lighting angle</b> .....	<b>1</b>	
1.1 Reflected light – bright field lighting .....	2	
1.2 Reflected light – partial bright field .....	3	
1.3 Dome lighting .....	4	
1.4 Dark field lighting .....	5	
1.5 Diffuse backlight .....	7	
1.6 Collimated and telecentric backlight .....	8	
<b>2. Wavelengths</b> .....	<b>11</b>	
2.1 Spectral sensitivity .....	12	
2.2 Colour theory in a nutshell .....	13	
2.3 Light and colour .....	14	
2.4 Light and colour – infrared .....	15	
2.5 Resolving capacity .....	16	
<b>3. Optical filters</b> .....	<b>19</b>	
3.1 Bandpass filters .....	20	
3.2 Polarisation filters .....	21	
3.3 Other optical filters .....	23	
<b>4. Strobe vs. continuous</b> .....	<b>27</b>	
4.1 Continuous and switch operation .....	27	
4.2 Strobe lighting .....	28	
4.3 Benefits of strobe lighting for industrial applications .....	30	
4.4 Key factors for strobe .....	33	
<b>5. Fluorescence applications</b> .....	<b>39</b>	
<b>6. Lighting systems for the standards-compliant reading (validation) and verification of codes</b> .....	<b>45</b>	
<b>7. Lighting technology for shape-from-shading applications</b> .....	<b>51</b>	
<b>Glossary</b> .....	<b>55</b>	



# 1. Influence of the lighting angle

A camera can only “see” what is made visible to its sensor by light. For this reason, the first and perhaps most important step is the selection of a suitable lighting geometry and the optimal angle at which to position the test object. Indeed, the appearance of an identical test object in the camera image can be drastically altered by the relative arrangement of camera, test object and lighting.

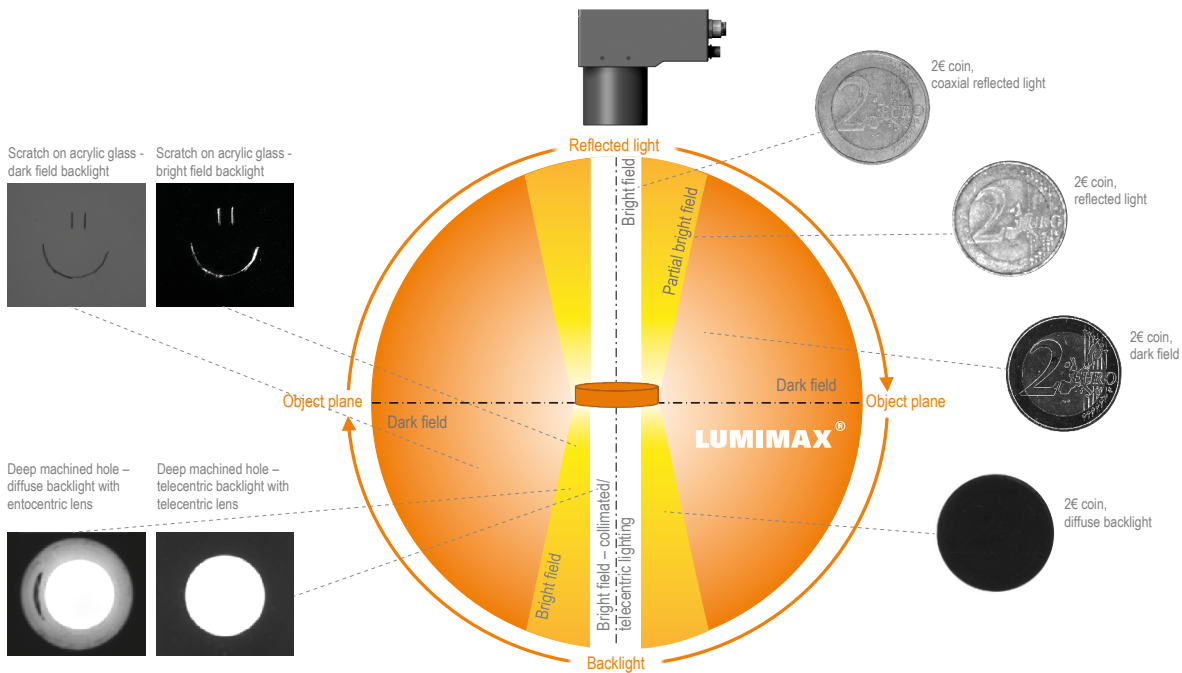

When selecting the type of lighting and its arrangement, there is a fundamental difference between

- **reflected-light lighting**, which comes from the direction of the camera and is thus positioned above the object plane; and
- **backlight lighting**, which is positioned behind the test object.

When choosing a lighting arrangement for reflected light, the ground rule is the Law of Reflection – which you probably still remember from school. This in itself is naturally common knowledge. Yet the awareness – and more importantly, application – of this simple law when selecting an appropriate lighting type and arrangement is really and truly half the battle.

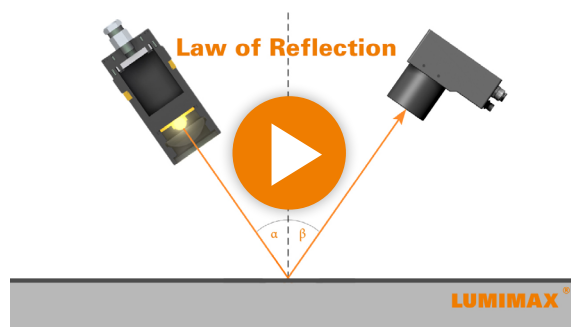

Video can be viewed at <https://www.iim-ag.com/en/lumimax/useful-facts/videos/video-law-of-reflection.html>

The first chapter of the LUMIMAX<sup>®</sup> Knowledge Base tells you everything you need to know about lighting types and angles, as well as how they affect your Machine Vision solution.

Influence of the lighting angle

Wavelengths

Optical filters

Strobe vs. continuous

Fluorescence applications

Lighting systems for the reading and verification of codes

Lighting technology for shape-from-shading

## 1.1 Reflected light – bright field lighting

Bright field lighting is a type of reflected-light lighting. Imagine the object plane as a perfectly flat reflector. If the lighting is arranged so that light is reflected directly back into the camera, this is referred to as a bright field arrangement.



Partial bright field



Bright field arrangement

This type of lighting is therefore especially suited to:

- Surface finish inspection
- Imaging of embossed, dot-peened und laser-cut characters and codes

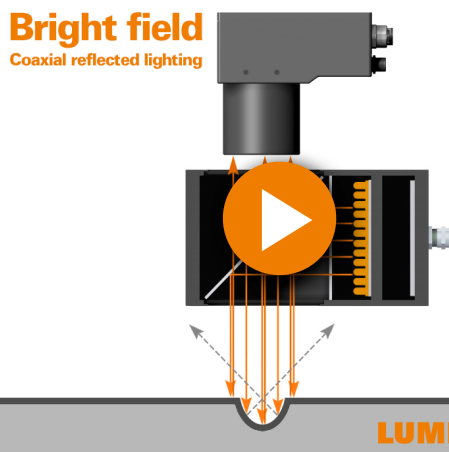

One way to achieve a bright field setup is to use coaxial reflected lighting, for example. For this type of lighting, a diffuse, homogeneous light source is mounted over a semi-transparent reflector directly in the beam path of the lens.

This provides very homogeneous, shadow-free lighting for the object. The light beam hits flat surfaces vertically and is reflected directly back into the camera. Surface irregularities deflect the light, however, and therefore appear dark.

The type of lighting is recommended for illuminating strongly reflective and mirror-like surfaces.

Video can be viewed at <https://www.iim-ag.com/en/lumimax/useful-facts/videos/video-bright-field-coaxial-lights.html>

On each pass through the reflector, however, 50% of the light output is lost. Accordingly, only 25% of the light transmitted reaches the camera. To achieve a well-lit, high-contrast image nonetheless, the coaxial reflected lighting is used at a short distance from the test object.

An alternative bright field arrangement, also suitable for larger working distances as well as matt and rough surfaces, is based on the Law of Reflection as explained in “Chapter 1 – Influence of the lighting angle”:

angle of light incidence  $\alpha$  = angle of light reflection  $\beta$

If the lighting is positioned at a certain angle to the object plane, the camera must be tilted to the same angle – but in the opposite direction to the perpendicular. In this way, the light beam hits flat surfaces vertically and is reflected directly back into the camera.

As with coaxial reflected lighting, the light beam is deflected by irregularities, which means that these will be shown as dark areas on an otherwise bright background.



Video can be viewed at <https://www.iim-ag.com/en/lumimax/useful-facts/videos/video-bright-field-high-power-spot-lights.html>

Influence of the lighting angle

Wavelengths

Optical filters

Strobe vs. continuous

Fluorescence applications

Lighting systems for the reading and verification of codes

Lighting technology for shape-from-shading

## 1.2 Reflected light – partial bright field

The partial bright field arrangement is the lighting setup that is most commonly used. Unlike the bright field arrangement described in chapter 1.1, the angles of incidence and reflection are less important in this lighting setup. A camera-mounted ring light is used to produce the light beam or spot/area lighting is used to direct light onto the test object at a slight angle:

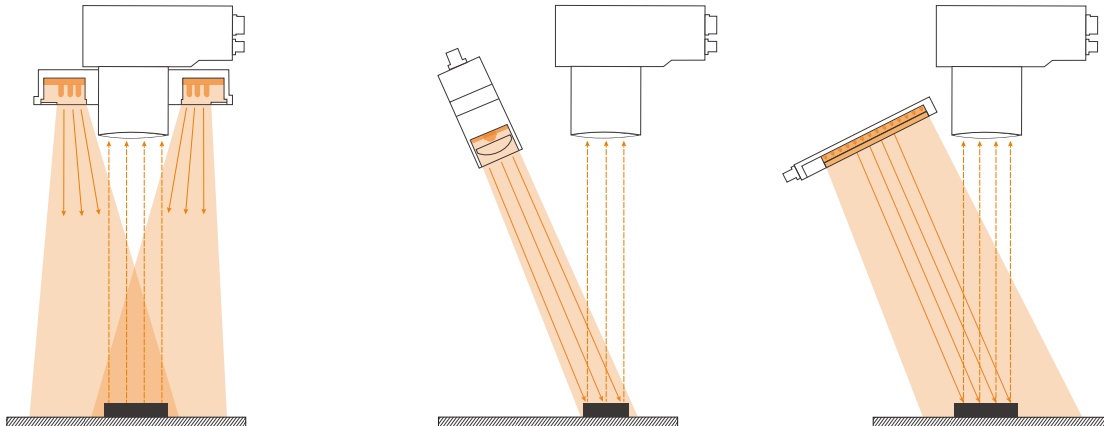

The goal of this type of illumination is not to highlight surface defects, edges or irregularities: instead, this approach aims to provide homogeneous, intense light over the entire image field. As such, the partial bright field setup is especially suited to the uniform lighting of rough and matt objects.

### Typical applications for a partial bright field arrangement:

- Assembly, type and position detection
- Printed material inspection
- OCR/OCV

Thanks to a wide variety of lighting accessories, including diffusor plates, polarisation filters and Fresnel lenses, the lighting setup can be adjusted to accommodate a huge variety of application specifications and ambient conditions.

For large working distances and strongly absorbent objects, High Power LED Lighting is especially suitable. Very high intensity LEDs, combined with integrated controller and performance electronics guarantee luminous intensities of well over 5 million lux in strobe operation and offer excellent lighting for the objects under inspection – even at a working distance of several metres.



Changing a lens array of the LUMIMAX<sup>®</sup> Area Lighting LQHP80

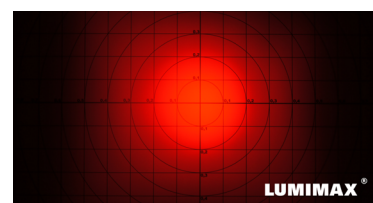
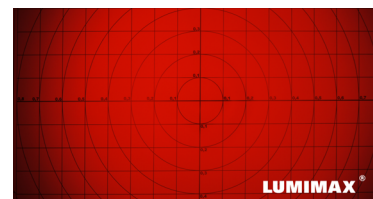

High Power Lighting: left with 49° lenses, right with 10° lenses (at a working distance of 1.5 m)

Since the lenses in front of the LEDs can be swapped out in LUMIMAX<sup>®</sup> High Power LED Lighting, the lighting setup can be adjusted to meet a broad range of requirements. By using lighting with a tight beam angle, for example, objects several metres away can still be lit at a high luminous intensity. A broad beam angle, on the other hand, creates homogeneous lighting even at shorter distances, while also providing high-intensity lighting for larger objects.

Influence of the lighting angle

Wavelengths

Optical filters

Strobe vs. continuous

Fluorescence applications

Lighting systems for the reading and verification of codes

Lighting technology for shape-from-shading

## 1.3 Dome lighting

Shadow-free lighting is a special form of reflected-light lighting, in which diffuse light falls onto the test object from all directions. This can be used to create lighting that is completely free of shadows. To achieve this effect, light from the light source does not fall directly on the object. The light rays are directed at a dome-shaped reflector, which reflects these onto the test object from all directions. The cupola-shaped reflector gives this type of lighting its name: dome lighting.

This lighting scenario can be usefully compared to the light on a cloudy day. On a bright but cloudy day, it can occasionally seem as if light is coming from all directions at once. The exact location of the sun is not clear. Here, the clouds are acting as both a diffusor and a reflector, and creating homogeneous, omnidirectional lighting. No shadows are cast outside.

**Dome lighting is especially suitable for:**

- Surface finish inspection, even on convex objects
- Inspection of diffuse but strongly reflecting and mirror-like surfaces
- Assembly, type and position detection
- Printed material inspection
- Code scanning
- OCR/OCV

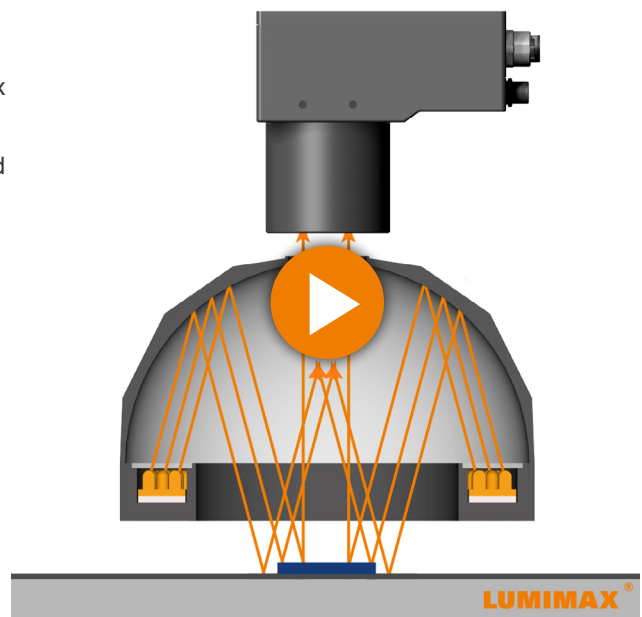

Video can be viewed at <https://www.iim-ag.com/en/lumimax/useful-facts/videos/video-dome-lights.html>

Shadow-free lighting is especially suitable for the high-quality imaging of glossy surfaces with a complex structure. One example use is creating homogeneous lighting for highly reflective packaging with buckling and irregularities, so as to enable print quality inspection.

The limitation when using this type of lighting is the working distance. To ensure shadow-free illumination, this distance must be kept as short as possible. Convex and globe-shaped objects may even need to be fully enclosed by the lighting setup.



Back of a tablet blister pack – reflected light

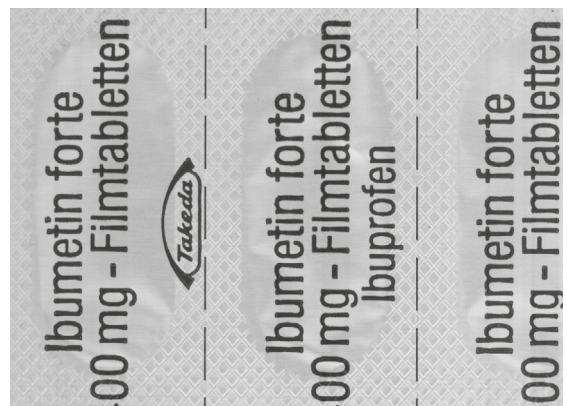

Back of a tablet blister pack – dome lighting

Influence of the lighting angle

Wavelengths

Optical filters

Strobe vs. continuous

Fluorescence applications

Lighting systems for the reading and verification of codes

Lighting technology for shape-from-shading

## 1.4 Dark field lighting



Left: diffuse reflected light

Right: Dark field

Dark field lighting is therefore especially suitable for:

- Surface finish inspection, even for strongly reflective objects
- Inspection of dot-peened or laser-cut codes
- Inspection of engraving, embossing, stamped numbers and raised structures
- Edge inspection

In direct contrast to bright field lighting, a dark field lighting setup is arranged so that light reflected by the surface of the test object is directed away from the camera. Accordingly, the object in the image appears dark. If the beam of light falls on an irregularity, however, then its edges will deflect the light rays. Accordingly, defects, contours or edges will appear as bright features on a dark background.

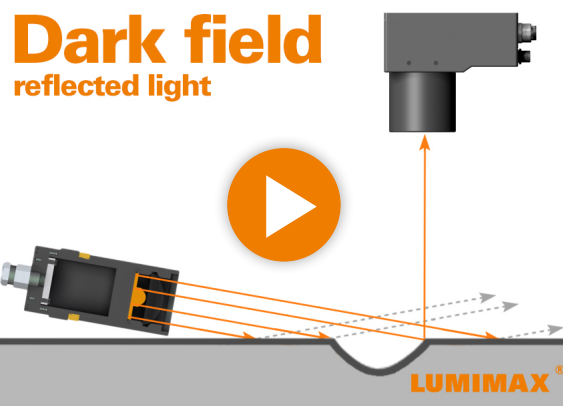

Video can be viewed at <https://www.iim-ag.com/en/lumimax/useful-facts/videos/video-dark-field-light-reflected-light.html>

To achieve a dark field arrangement, special ring lighting systems can be used. These use a radial light source that produces light at a flat angle. Another variant is creating a dark field with spot or bar lighting systems arranged at low angles of incidence.

The variant used depends not only on the test object itself, but also on the local installation conditions. Since a light source with a low angle of incidence means that dark field lighting utilises a very short working distance, using a closed ring light source is not always possible. In such cases, a combination of bar lights is typically used for lighting instead.



LUMIMAX® LSB series bar lights in the mounting bracket

The LUMIMAX® Miniature Bar Lights in the LSB series are the perfect choice for this specific use case. Thanks to a special lens fitted in front of the LEDs, which is carefully matched to dark field requirements, these lights are able to achieve a homogeneous yet directed bar of light. Another special feature is the innovative mounting solution, which can incorporate one to four bar lights arranged in a square formation. The incident angle of the bar lights to the object plane can be altered between 0° and 90° in steps of 7.5°. The lights lock into place in each position, creating a precise, reproducible configuration, and ensuring that the lighting can be adjusted flexibly to a wide range of requirements.

Influence of the lighting angle

Wavelengths

Optical filters

Strobe vs. continuous

Fluorescence applications

Lighting systems for the reading and verification of codes

Lighting technology for shape-from-shading

## 1.4 Dark field lighting

In special cases, the lighting is also placed as a dark field behind the object. This approach is used to highlight defects in semi-transparent or transparent test objects. As with the reflected light version of dark field lighting, the light here is also normally reflected away from the camera. If the light falls on a scratch or edge, however, the beam is deflected into the camera.

In practice, however, backlight dark field lighting is a less commonly used arrangement.

Influence of the lighting angle

Wavelengths

Optical filters

Strobe vs. continuous

Fluorescence applications

Lighting systems for the reading and verification of codes

Lighting technology for shape-from-shading

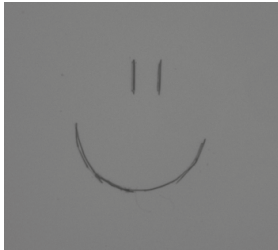

Scratch on acrylic glass – diffuse backlight

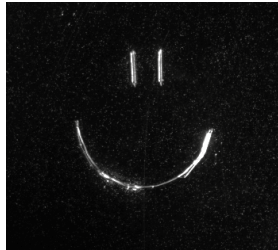

Scratch on acrylic glass – dark field backlight

### Dark field Backlight

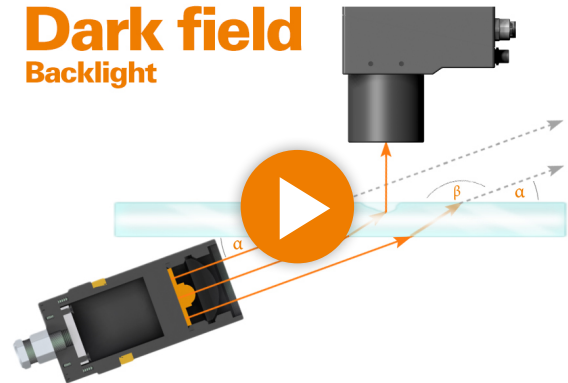

**LUMIMAX**<sup>®</sup>



Video can be viewed at <https://www.iim-ag.com/en/lumimax/useful-facts/videos/video-dark-field-light-backlight.html>

## 1.5 Diffuse backlight

With this form of lighting, a diffuse light source is positioned behind the object. Unlike reflected-light lighting, this means the contours of the object are lit instead of the object itself.

A "shadow image" is the result. In the shadow image created, the object's outline and (open) inside contours are readily visible. The object appears as a black area in front of a white background. The high level of contrast achieved hugely simplifies the subsequent image analysis.

### Backlight diffuse

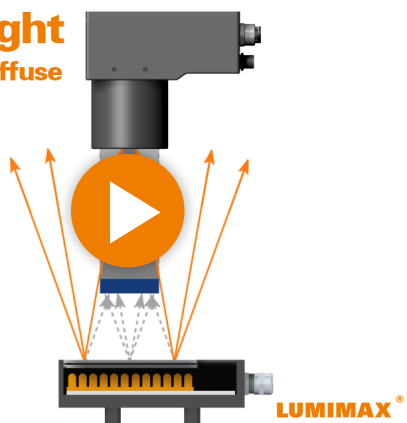

Diffuse backlight lighting is primarily used in the following applications:

- Contour inspection
- Presence inspection
- Machined hole inspection
- Orientation/rotary orientation inspection
- Residual soiling analysis

Video can be viewed at <https://www.iim-ag.com/en/lumimax/useful-facts/videos/video-diffused-backlight.html>

In addition, diffuse backlight lighting is also useful for the imaging of transparent and semi-transparent objects. This can be used to check the fill levels of bottles and jars during filling, for example. With longwave light, this approach even works with transparent liquids such as water. Diffuse backlight lighting is also well-suited to applications requiring the high-contrast imaging of defects or features in diaphanous glass or plastics.

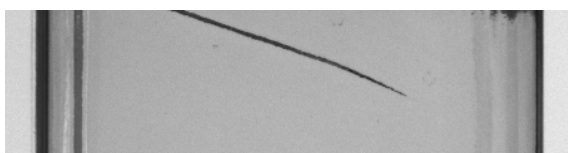

Rotary orientation detection for a glass surface in backlight using an edge in the glass

Both scratches in glass and features such as embossing or grinding can be imaged using this form of backlighting. With the help of polarisation filters, the current range of possible applications now even includes testing glass for stress fractures.

For diffuse backlight applications, the recommended light source is a diffuse, homogeneous form of area lighting. Since the size of the light field must be adjusted to the object size for most kinds of application tasks, large area lighting systems are typically used. New technologies, such as the lateral coupling of LEDs into optical fibre, permit the creation of homogeneous, high-intensity lighting systems with lengths of 1 m or more to a side. This technology is used in LUMIMAX® Lighting in the LG series.



Punched part in backlight



Machined hole inspection

Influence of the lighting angle

Wavelengths

Optical filters

Strobe vs. continuous

Fluorescence applications

Lighting systems for the reading and verification of codes

Lighting technology for shape-from-shading

## 1.6 Collimated and telecentric backlight

The diffuse backlight lighting introduced in chapter 1.5 utilises the principle of the Lambertian scatterer\* to generate a constant radiance over the spatially extended lighting field. The light has no preferred direction of propagation and scatters evenly and homogeneously in all directions. Although required for many applications, this can pose a problem during precise measurement work, for example.

For spatially highly extended objects and round outer edges, non-directional lighting generates a partial shadow. Instead of a binary transition from white to black in the image, the result is a grey gradient over several pixels. This makes determination of the exact edge location more difficult.

### Backlight diffuse

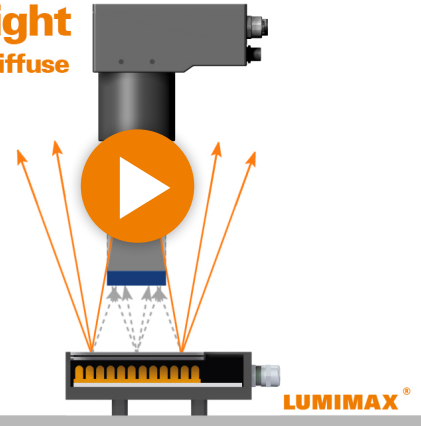

Video can be viewed at <https://www.iim-ag.com/en/lumimax/useful-facts/videos/video-diffused-backlight.html>

### Backlight collimated

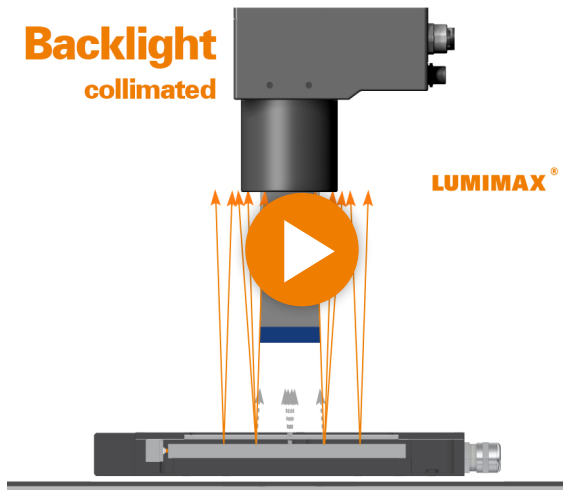

Video can be viewed at <https://www.iim-ag.com/en/lumimax/useful-facts/videos/video-collimated-backlight.html>

To solve this problem, we can work with directed, homogeneous, backlight lighting. With this type of lighting, the beam angle of the light is reduced by using special optical films. This very nearly approximates collimation. The effect achieved with backlighting is similar to that obtained by telecentric lighting. The light rays from the lighting are significantly more directed and achieve a more precise image of object edges. Edge probing is consequently more exact than with diffuse backlight. For deep objects and objects with convex edges in particular, this can optimise the determination of the exact edge location and improve the accuracy of the Machine Vision system.

Collimated backlight lighting also has advantages when working with transparent and semi-transparent test objects. The directed rays of light are refracted more directly by edges and irregularities. These therefore appear as pronounced areas of darkness against a bright background. This simplifies the detection of scratches, inclusions, embossing and engravings in glass or plastics.

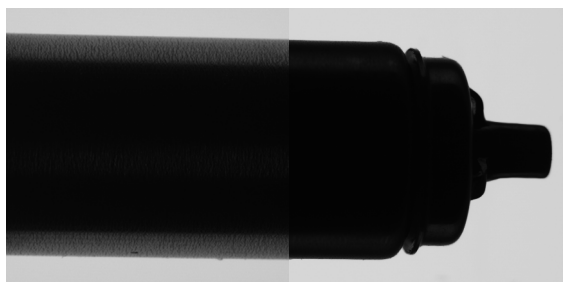

Metal cylinder – diffuse backlight

collimated backlight

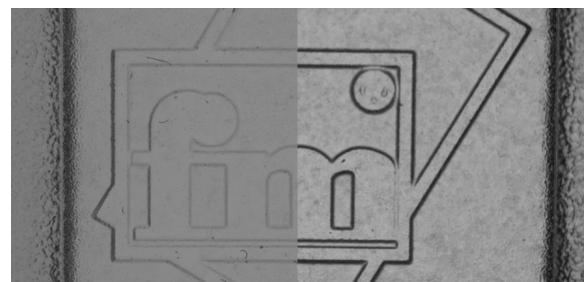

Transparent plastic with embossing – diffuse backlight

collimated backlight

\* For a precise definition of terms, see the Glossary on the last page of this Knowledge Base.

Influence of the lighting angle

Wavelengths

Optical filters

Strobe vs. continuous

Fluorescence applications

Lighting systems for the reading and verification of codes

Lighting technology for shape-from-shading

## 1.6 Collimated and telecentric backlight

This effect can be enhanced by the use of telecentric backlight lighting. Collimation is achieved by using an optical system in front of a divergent source of light radiation. The beams of light from this telecentric lighting run parallel to one another.

### Telecentric backlight

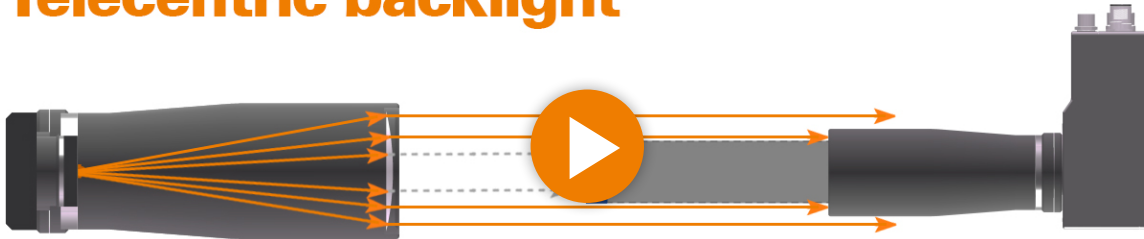

Video can be viewed from <https://www.iim-ag.com/en/lumimax/useful-facts/videos/video-telecentric-backlight.html>

**LUMIMAX**<sup>®</sup>

By using a telecentric lens, exactly this parallel light – which runs perpendicular to the plane of the image sensor – is recorded and passed on to the camera. The result is a bright image. If an object is located between the lighting and the lens, this object appears in the image as a perfectly dark body. Edge transitions are clear and extend over only a few pixels from bright to dark. This makes edge probing both straightforward and highly accurate.

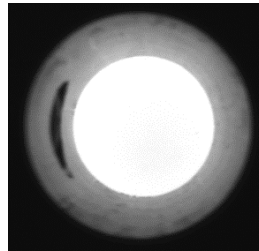

Deep machined hole –  
diffuse backlight

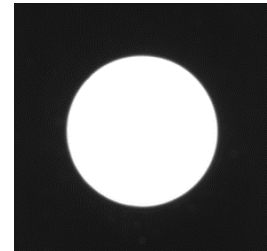

telecentric backlight

As with directed homogeneous backlight lighting, the outlines of transparent objects can be captured as sharp images by using telecentric lighting. Here, the bundle of parallel rays crosses only the perpendicular planes of a body. These appear bright in the image while all other areas are dark. The object's outline is therefore dark in the image. A similar result is achieved with irregularities such as scratches or inclusions in transparent test objects.



Transparent pen refill –  
diffuse backlight



telecentric backlight

Use of telecentric lighting also significantly enhances the depth of field and the telecentric region of a telecentric lens.

Influence of the  
lighting angle

Wavelengths

Optical filters

Strobe vs.  
continuous

Fluorescence  
applications

Lighting  
systems for the  
reading and  
verification  
of codes

Lighting  
technology for  
shape-from-  
shading



## 2. Wavelengths

Apart from the light geometry and the lighting angle, selecting the right lighting is also crucially dependent on the light's wavelength. This point is often neglected, however. Yet it is precisely this factor that can ultimately be decisive for your application.

The colour of the light is by no means only important when working with colour cameras.

For monochrome image acquisitions of colour objects in particular, surprising effects can be achieved.

In addition, the wavelength also directly affects image resolution capabilities. While shortwave light can render the ultrafine structures visible, longwave light has the ability to mask interference patterns.

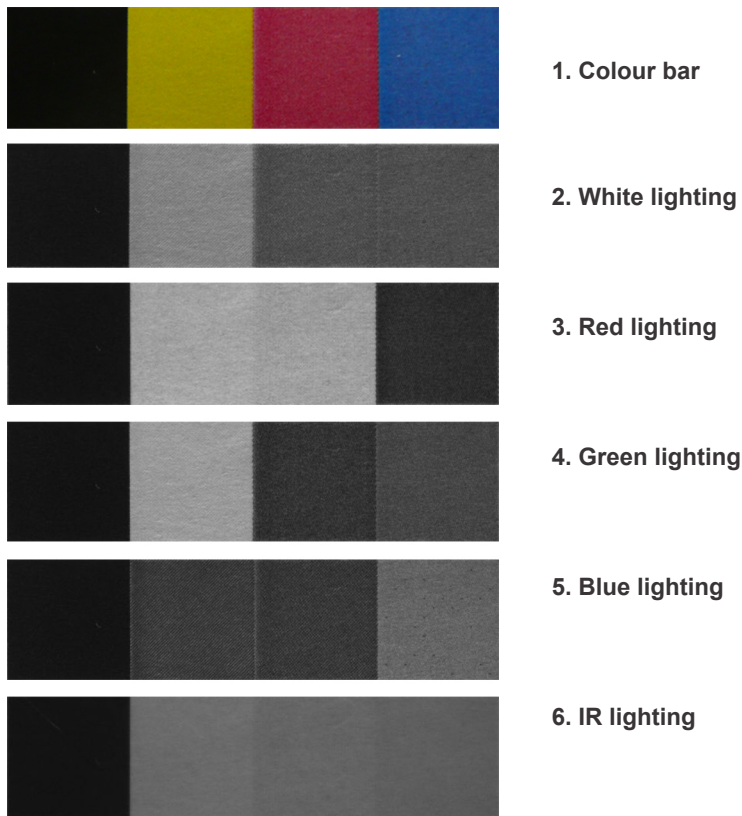

Colour bar under light at various wavelengths

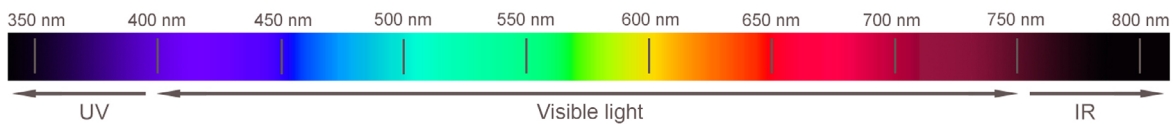

To demonstrate how a few tricks and the right light colour can be used to optimise application solutions, this chapter in the LUMIMAX<sup>®</sup> Knowledge Base focuses on the topic of wavelengths.

Influence of the lighting angle

Wavelengths

Optical filters

Strobe vs. continuous

Fluorescence applications

Lighting systems for the reading and verification of codes

Lighting technology for shape-from-shading

## 2.1 Spectral sensitivity

The diagram below shows the sensitivity curve for the human eye – also known as the V-lambda curve – plotted against the spectral sensitivity of a CCD sensor. The human eye perceives radiation from around 400 to 700 nm as visible light. The eye is most sensitive at around 555 nm. Accordingly, less radiation intensity is required in the middle of the V-lambda curve than at the extremes of the curve to achieve the same brightness. The camera sensor responds to a much broader range of the electromagnetic radiation spectrum. As a result, the camera is also sensitive to ultraviolet and infrared wavelengths, which are invisible to the human eye.

### Relative spectral sensitivity

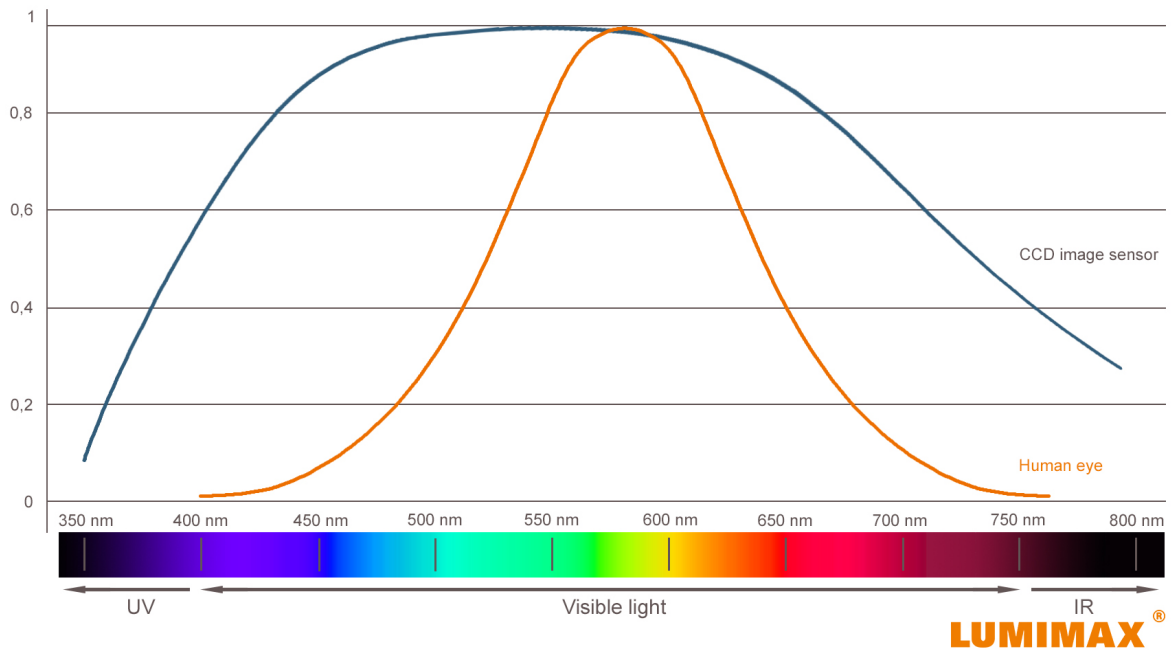

An appreciation of this difference is essential when designing lighting that is suitable for an image processing task. Often, the brightness of a lighting system is given as illuminance, measured in lux. This value for illuminance describes the luminous flux (lumens per square metre) that falls on a surface from the light source. The value for illuminance is one lux if a square metre of this surface is illuminated with a luminous flux of one lumen. Accordingly, 1 lumen/square metre is equal to 1 lux. Caution is advised, however: when measuring illuminance, the V-lambda curve is used as a weighting factor. Accordingly, green light has a higher lux value than blue or red for the same amount of light energy. Accordingly, illuminance is both a visual and photometric parameter. While room lighting may be perfectly adequate if only perceived by the eye, this can cause unexpected results for Machine Vision. Since the spectral sensitivity of the camera does not match that of the eye, this parameter is a less useful indicator for the field of industrial Machine Vision.

A more dependable value is the objective, energetic indicator of irradiance. This describes the sum total of electromagnetic energy or optical radiation energy that falls as light onto the surface. The value is given in watts per square metre. From this particular perspective, the sensitivity of the human eye is not considered at all. As a result, irradiance is a significantly more reliable criterion when needing to assess lighting systems for an image processing task in terms of their brightness.

Influence of the lighting angle

Wavelengths

Optical filters

Strobe vs. continuous

Fluorescence applications

Lighting systems for the reading and verification of codes

Lighting technology for shape-from-shading

## 2.2 Colour theory in a nutshell

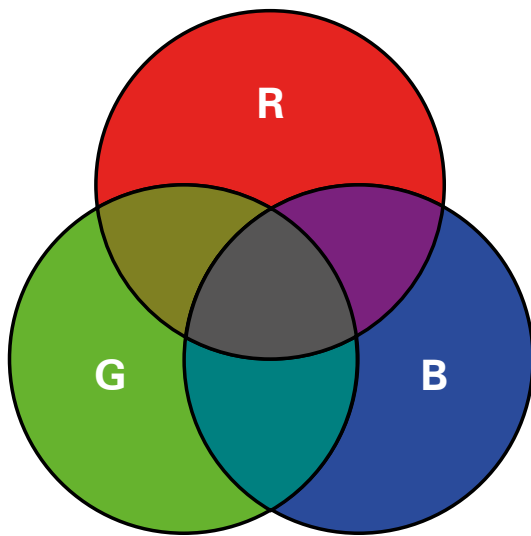

Subtractive colour mixing

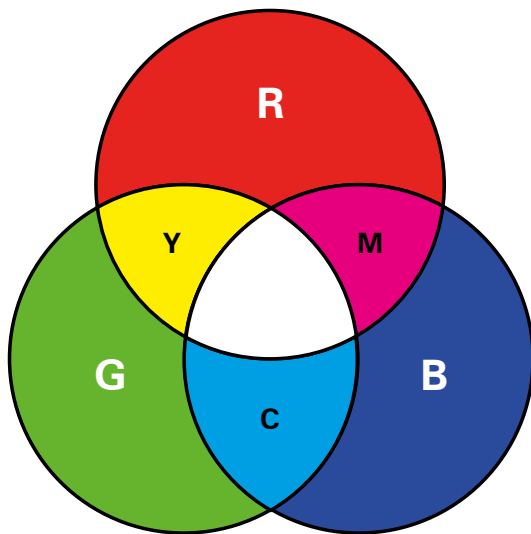

Additive colour mixing

To appreciate how light and colour interact, we first need to understand the basic scientific principles on which this depends.

The first important point is colour mixing. The primary colours are red, green and blue – just as we learned in school. The more of each colour we mix together, the darker that the resulting mixed colours will be.

If all three primary colours are mixed in equal proportions, we get black. This kind of colour mixing is known as subtractive, and can be applied to all methods in which colour pigments are mixed together.

When we work with light, we refer instead to additive colour mixing. If we mix together red, green and blue light in equal proportions, we get white light. Red and green light in equal proportions without any blue light will produce yellow, while red plus blue makes magenta, and blue plus green makes cyan. We need this knowledge in order to understand how coloured bodies interact with coloured light. We will look at this topic in chapter 2.3.

White light is therefore composed of a mixture of the three wavelengths red, green and blue. Accordingly, it logically follows that white light cannot be given a wavelength itself. Instead, the classification of white light relies on the colour temperature. This is specified in Kelvin and corresponds to the temperature of a black body, or black-body radiator\*. The black body perfectly absorbs all electromagnetic radiation. If it is heated, however, it begins to glow and therefore produce light in the visible spectrum. The temperature at which this occurs is the colour temperature.

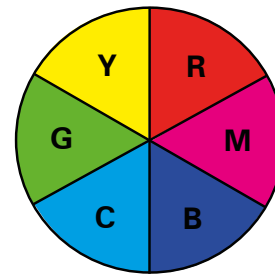

Colour wheel

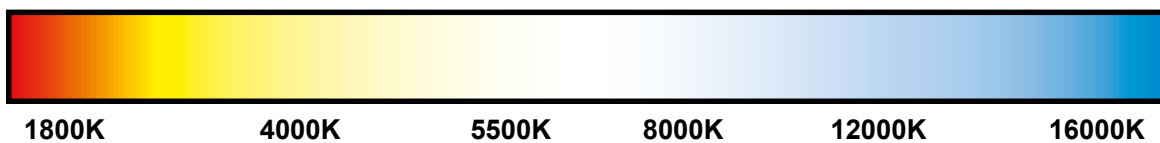

Colour temperature in kelvins (K)

Influence of the lighting angle

Wavelengths

Optical filters

Strobe vs. continuous

Fluorescence applications

Lighting systems for the reading and verification of codes

Lighting technology for shape-from-shading

\* For a precise definition of terms, see the Glossary on the last page of this Knowledge Base.

## 2.3 Light and colour

Influence of the lighting angle

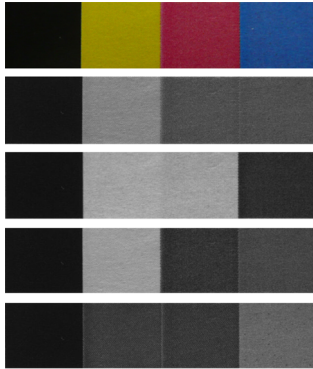

Colour bar illuminated with various wavelengths

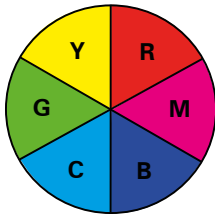

Colour wheel

Wavelengths

Optical filters

Strobe vs. continuous

Fluorescence applications

Lighting systems for the reading and verification of codes

Lighting technology for shape-from-shading

In chapters 2.1 and 2.2, we covered some basic theoretical principles related to light, wavelength and colour. We now want to use this chapter to bring these concepts together and relate them to the topic of image processing. Especially in the case of image processing tasks involving coloured objects and backgrounds, choosing the right wavelength is an important aspect. Particularly when using monochrome cameras, use of the right light colour can achieve effects that decisively improve solutions to many Machine Vision applications.

Contrast is significantly improved in the object image without additional optical or software filters being needed. This considerably simplifies the image processing task.

The principle itself is very simple: an object reflects certain wavelengths and therefore appears coloured to the human eye. An object that we perceive as red therefore reflects the red portion of the light. Other wavelengths are instead absorbed.

Conversely, this means that lighting a red test object with red light will make the object bright in the image. If we illuminate it instead with a wavelength containing no red portion, the light will be absorbed and the object will appear dark.

If we take a second look at the colour wheel, this effect can easily be transferred for use on other colours and wavelengths. If a yellow object is irradiated with blue lighting, it appears black. When lit with red or green light, it reflects the red or green colour portions of the light. The object appears bright. Here, it is important to remember that white bodies reflect all wavelengths and black bodies absorb light most strongly. Accordingly, these bodies usually respond independently of the colour temperature.

Special cases apply to the non-visible spectrum, i.e. to infrared and ultraviolet light. These topics will be discussed in chapters 2.4 and 2.5.

The range of applications for coloured lighting is very broad indeed. Examples of its use include inspection of printing on products in the packaging industry, in the assembly of coloured plastic parts or for pick-and-place tasks involving coloured objects or backgrounds.

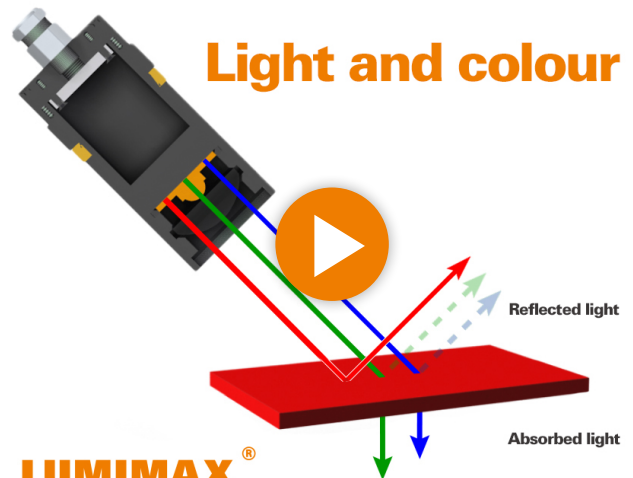

**LUMIMAX**<sup>®</sup>



Video can be viewed from <https://www.iim-ag.com/en/lumimax/useful-facts/videos/video-light-and-colour.html>

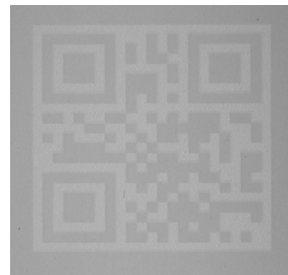

White QR code on red background under red light



White QR code on red background under blue light

## 2.4 Light and colour – infrared

In chapter 2.3, we looked at the interactions between various wavelengths and coloured objects. Special effects are encountered, however, when working with radiation outside the visible spectrum. In the long wave infrared range in particular, coloured and printed materials behaves differently than in the visible spectrum.

Both the reflection and absorption of infrared radiation is more dependent on the material and surface properties than on the material colour. Accordingly, an identical material will reflect and absorb to the same degree, regardless of its colouration. If light falls on a printed surface, for example, then the actual print present on the surface can be made almost entirely invisible to the camera. All colours will reflect this radiation uniformly. A similar effect is seen with various coloured plastics, labels – and even with many types of thermal transfer printing.

Black and white areas are one exception here. For these, the ground rule continues to apply: black is the strongest absorber of all wavelengths, while white reflects all wavelengths equally. As a result, black and white objects still appear black and white in the image. This means that infrared lighting can be used in conjunction with coloured objects to selectively mask certain areas.

### A practical example

In food packaging in particular, an appealing design is considered important, since it will encourage the consumer to buy the product. Accordingly, the design typically features an all-over, multi-coloured print. If a particular printed feature – such as the shelf life expiration date or a barcode – needs to be detected, this presents us with an image processing problem. This is where infrared lighting comes into play. Important markings such as the shelf life expiration date are often embossed or printed in black. If we exploit the effects of infrared radiation on colour, we can simply make a distracting background “fade away”. The overprint we need is brought into the foreground and can easily be analysed.

Apart from its usefulness with coloured test objects, this is not the only place where longwave infrared radiation has an important role to play. Infrared lighting can also be used to look inside certain kinds of materials. This technique is used in inspections using backlight systems on conveyor belts, for example. Infrared radiation can also be used in combination with specialised filters to attenuate (block) extraneous light. In chapter 3, this technique will be looked at in detail.



Aluminium cap for yoghurt pot under white light

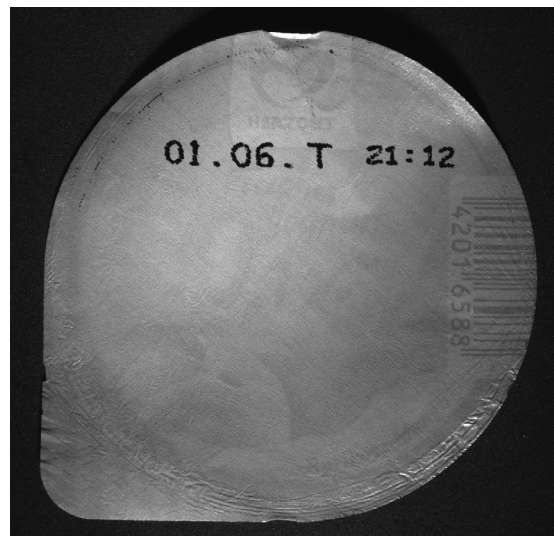

Aluminium cap for yoghurt pot under infrared radiation

Influence of the lighting angle

Wavelengths

Optical filters

Strobe vs. continuous

Fluorescence applications

Lighting systems for the reading and verification of codes

Lighting technology for shape-from-shading

## 2.5 Resolving capacity

The last few sections in this chapter have looked at the interactions of light with coloured objects. Yet the decision for or against a certain wavelength is not only of interest in the context of coloured test objects. For both reflected light and backlight systems, the choice of the right wavelength has a decisive role to play.

### Reflected light

When inspecting surfaces for features, damage and soiling – such as embossing, scratches or dust, for example – the use of shortwave light is recommended. This is reflected more strongly than longwave radiation, and can be used to make even minor irregularities clearly visible. Under longwave light, however, which penetrates more deeply into the material layers, these small surface defects are barely visible. The difference in contrast is minimal, which means that analysis using a Machine Vision system can not be implemented. One portion of the longwave light is reflected directly at the surface. The other portion is transmitted by the object surface and this is irradiated back only by deeper layers within the material. Reflection is more diffuse in comparison to shortwave light, which reflects directly on the material surface. In the test object image, object edges therefore appear comparatively less sharp. Effects increase proportionally as the wavelength of the radiation used becomes shorter or longer. For this reason, intensely blue or ultraviolet light is used for surface inspection work.

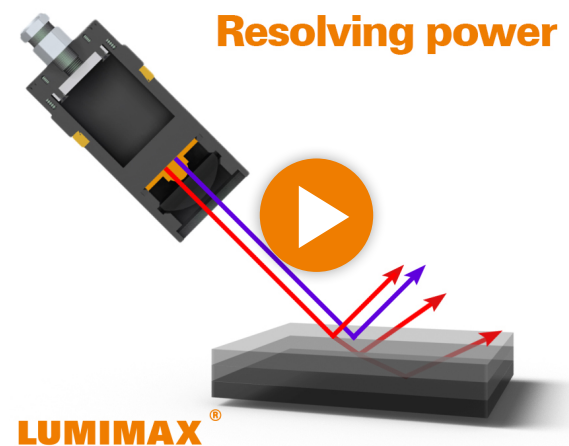

**LUMIMAX**<sup>®</sup>

Video can be viewed at <https://www.iim-ag.com/en/lumimax/useful-facts/videos/video-resolving-capacity.html>

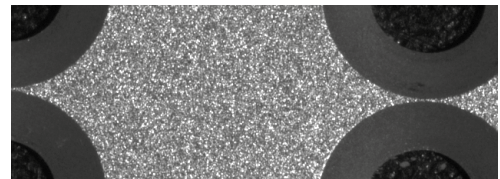

Scratch on anodised metal part under IR radiation

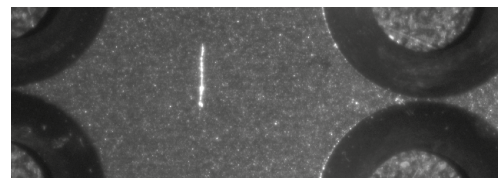

Scratch on anodised metal part under UV radiation



Influence of the lighting angle

Wavelengths

Optical filters

Strobe vs. continuous

Fluorescence applications

Lighting systems for the reading and verification of codes

Lighting technology for shape-from-shading

### Backlight

Nor should the effects of various wavelengths be overlooked for backlight systems. The primary concern here is light diffraction. Put simply, the diffraction effect is the propagation of light behind an edge. When light travelling as a wave hits an object, it will be deflected. Behind an object edge, the waves of light spread out in all directions and overlap one another. Diffraction will be more pronounced with longwave light. This is especially important for the imaging of objects and their edges, and taking measurements in backlight systems. If shortwave light is used instead, object edges will be imaged more sharply and with richer contrast, as shortwave light diffracts less strongly around the object. This minimises edge washout in the image while increasing Machine Vision measurement accuracy.

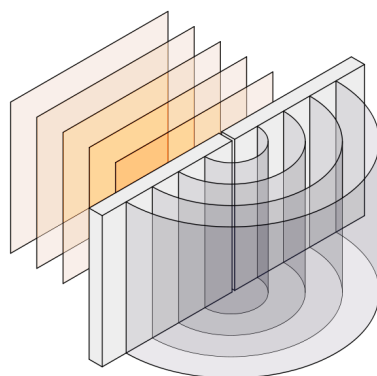

Wave diffraction at a slit  
Source: de.wikipedia.org





## 3. Optical filters

Chapters 1 and 2 have introduced the basic principles for selecting an optimal lighting solution. Results can be further improved by the use of optical filters.

An optical filter is used to alter the light in accordance with certain criteria. Depending on the kind of filter used, the passage of light is either permitted or blocked (attenuated).

Various optical filters are available for effects such as the following:

- Increasing the contrast in an image
- Suppressing extraneous light
- Minimising distractions such as reflections/specular reflections
- Colour separation

In this Knowledge Base, we will explain the three filters most commonly used.

### ■ Chapter 3.1 – Bandpass filters

Bandpass filters, also known as interference filters, separate out certain wavelengths. The selected wavelength passes through the filter. The remainder of the light is reflected and does not reach the image acquisition device. These filters are used to suppress extraneous light, for example, or for fluorescence applications.

### ■ Chapter 3.2 – Polarisation filters

Apart from being used to select certain wavelengths, filters can also be used to let light pass only if it is in a certain state of polarisation. This can be used to minimise problematic (specular) reflections.

### ■ Chapter 3.3 – Other filters

Apart from bandpass and polarisation filters, there are many other approaches to using filters to optimise the test object image.

Naturally, there is a multitude of optical filters and application scenarios in which they are used. Chapter 5 of this Knowledge Base will explain the use of special filters for fluorescence applications.

Feel free to contact us if you need any additional information or support when choosing a suitable filter for your application.

Influence of the lighting angle

Wavelengths

Optical filters

Strobe vs. continuous

Fluorescence applications

Lighting systems for the reading and verification of codes

Lighting technology for shape-from-shading

## 3.1 Bandpass filters

Influence of the lighting angle

Wavelengths

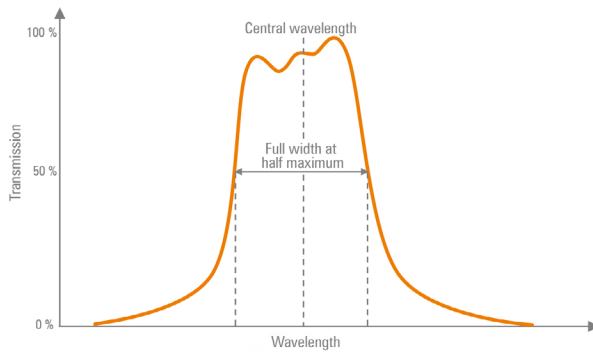

Parameters for a bandpass filter

cases where strobe lighting is not possible. When suppressing extraneous light, a daylight-cut filter is often used in conjunction with an infrared light source. These filters let infrared light pass, but attenuate (“cut”) the entire visible and ultraviolet spectrum. This works to minimise the effects of daylight on the Machine Vision solution.

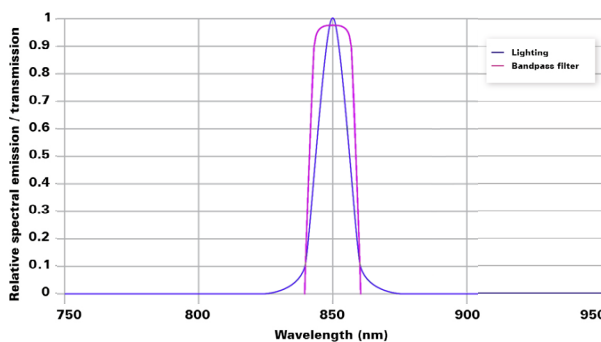

A bandpass filter transmits a specific wavelength region. The remaining light is attenuated. The breadth of this transmission band is selected according to the intended purpose. There are filters with a bandwidth of less than 2 nm and filters with bandwidths of 80 nm or more. Narrow bandpass filters with widths between 2 and 5 nm are primarily used in highly demanding laser-based applications. On the other hand, filters with a bandwidth of 10 to 80 nm can be utilised for a range of applications of interest for Machine Vision. One of the most important areas in which they are used is eliminating extraneous light – especially in

Since visible-light wavelengths are often required for a wide range of tasks, however, extraneous light cannot always be suppressed by using a daylight-cut filter. Instead, a narrow bandpass filter can be used. This involves mounting a bandpass filter precisely matched to the wavelength of the lighting system in front of the lens or the image capture device. The more accurately the filter’s central wavelength matches the LED wavelength, the narrower the filter bandwidth that can be chosen. In consequence, as much light as possible is transmitted from the lighting system, while stray

light is blocked entirely. Narrow-band filters are equally good at improving image stability for infrared lighting in comparison to standard daylight-cut filters. High-quality filters with specific compatibility are available for LUMIMAX<sup>®</sup> LED Lighting.

By permitting certain wavelengths to pass and attenuating other wavelengths, bandpass filters can also be used to increase the contrast in an image or separate out colours.

One special field of application for these types of filters is fluorescence. We will be looking at this more closely in chapter 5, and offering you a number of interesting examples.

Bandpass filter for suppressing extraneous light

**Central wavelength (CWL)**

The central wavelength specifies the midpoint of the two wavelengths at which 50% of the maximum transmission is achieved.

**Full width at half maximum (FWHM)**

The full width at half maximum describes the width at which 50% of maximum transmission is achieved.

**Bandwidth**

The bandwidth refers to the wavelength region that is transmitted (passed) by the filter.

**Blocking range**

The blocking range describes the wavelength region that is rejected (stopped) by the filter.

**Optical density**

The optical density describes the filter’s power to reject wavelengths. Filters with a high optical density have a lower rate of transmission than those with a lower optical density.

Parameters for a bandpass filter

Lighting systems for the reading and verification of codes

Lighting technology for shape-from-shading

## 3.2 Polarisation filters

When working with light, distracting reflections in the camera image – caused by lubricants, foils, paints or simply by reflections from glossy or mirror-like surfaces – are a recurrent problem. These distracting effects can be suppressed by the use of polarisation filters.

Polarisation describes the process by which light is restricted to a single direction of oscillation. Various options are available for achieving polarisation to improve an image within Machine Vision systems.

### Polarisation by using polarisation filters

In industrial Machine Vision, systems usually work with two linear polarisation filters. One is located in front of the light source and a second in front of the lens.

The light emitted by the lighting can oscillate in all directions. The polarising filter in front of the lighting transmits light in just one oscillation direction, however. Light rays with other oscillation directions cannot pass through the filter. If another filter is now placed in front of the lens, then the polarised light can either be allowed to pass or attenuated, as required.



**LUMIMAX**<sup>®</sup>



Video can be viewed at <https://www.iim-ag.com/en/lumimax/useful-facts/videos/video-polarization-filter.html>



Reflective label on a syringe in reflected light



Compare with: Reflective label on a syringe in polarised reflected light

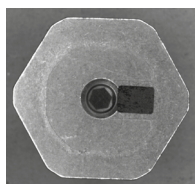

Film on metallic background in unpolarised reflected light

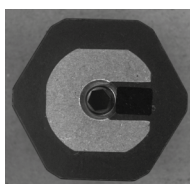

Film on metallic background in polarised reflected light

Polarised light is especially useful for suppressing distracting reflections. At the opposite end of the system – the lens – a second polarisation filter is set up as an attenuating filter. This acts to minimise reflections, and the camera image lighting is significantly more homogeneous. Since this kind of setup results in a lot of light being lost, however, working with especially powerful lighting systems – such as High Power Lighting – is strongly recommended.

Another approach involves exploiting the surface properties of various types of objects. As just one example, this can be used to make transparent films such as adhesive pads or labels visible on metallic backgrounds. While the metallic background reflects the polarised light back into the camera, the film changes the direction of polarisation for the incident light. Accordingly, if the polarised light is blocked at the camera, only the film remains bright and can therefore be easily detected.

Influence of the lighting angle

Wavelengths

Optical filters

Strobe vs. continuous

Fluorescence applications

Lighting systems for the reading and verification of codes

Lighting technology for shape-from-shading

## 3.2 Polarisation filters

Polarised lighting is not only suited to reflected light. With a polarised backlight system, even transparent plastics and glass can be made visible. If the lens filter is configured as an attenuating filter, a dark image is first obtained. If a transparent object is present in the image, however, then this changes the oscillation direction of the light and it appears bright before the dark background. Even the arrangement of stress fractures in the objects can be identified, since these change the oscillation direction yet again.

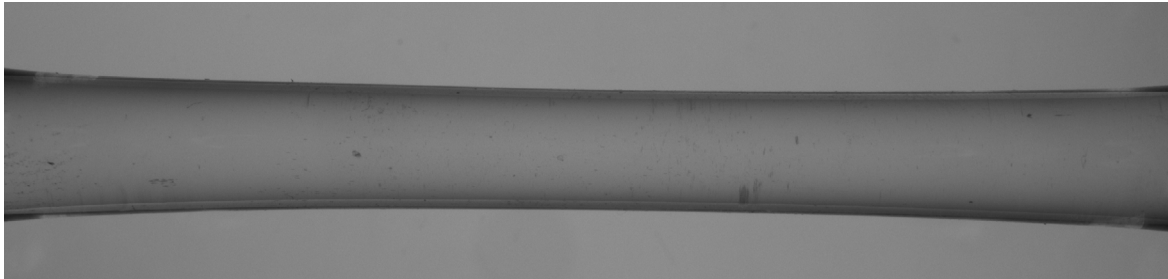

Glass in unpolarised backlight

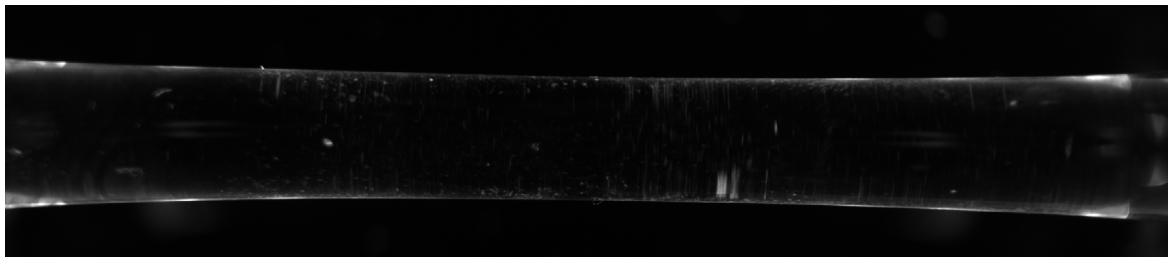

Glass in polarised backlight

### Polarisation by the surface

If the polarisation angle – or Brewster's angle\* – is taken into account, then the surface of the test object itself can actually be used to polarise the light emitted by the lighting system. If the light falls onto a non-metallic surface at this particular angle, then the reflected portion of the light will be polarised parallel to the surface. If a polarisation filter has been set up as an attenuating filter in front of the lens – i.e. rotated 90° – this can suppress distracting surface reflections.

\* For a precise definition of terms, see the Glossary on the last page of this Knowledge Base.

Influence of the lighting angle

Wavelengths

Optical filters

Strobe vs. continuous

Fluorescence applications

Lighting systems for the reading and verification of codes

Lighting technology for shape-from-shading

## 3.3 Other optical filters

Apart from the optical filters already described, there is a wide variety of other filter techniques available for optimising the test object image.

### 1. Shortpass filters

Shortpass filters transmit wavelengths that lie below the filter's threshold wavelength. Wavelengths above the threshold wavelength are attenuated. Shortpass filters are frequently used to separate wavelengths from one another and increase contrast in the image.

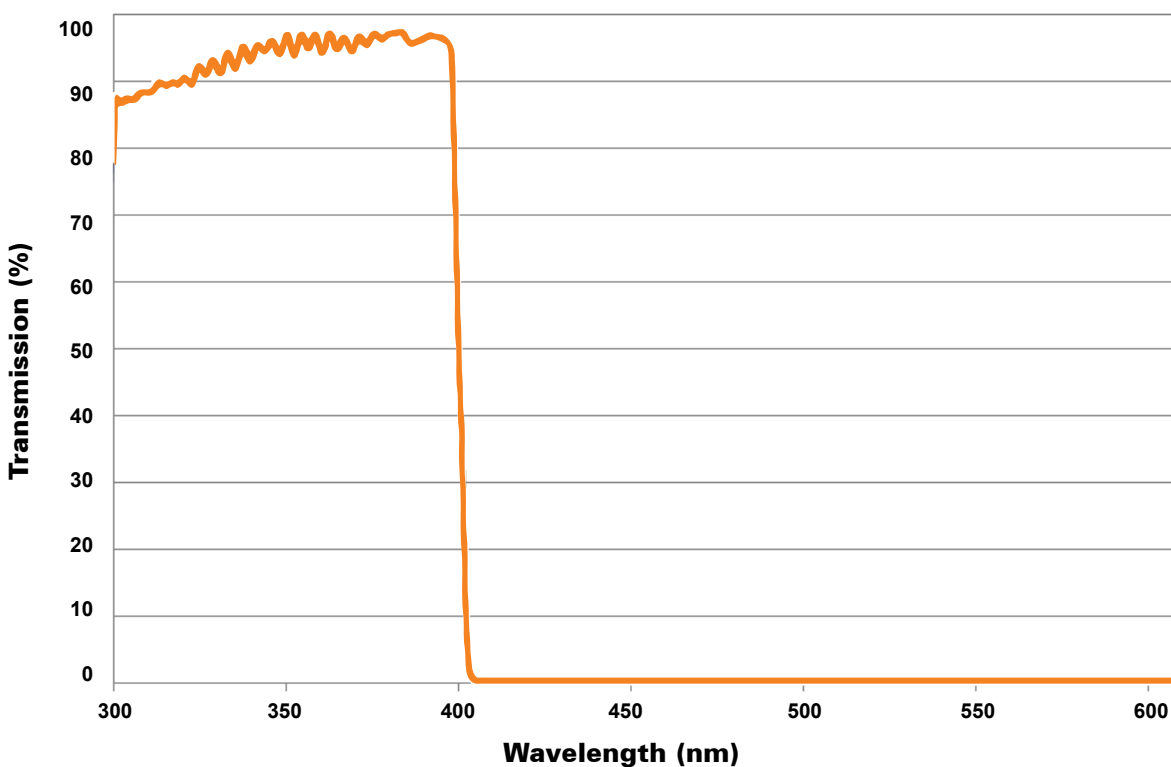

They can also be used as lighting filters in fluorescence applications. If a shortpass filter of this kind is used with a very sharp slope as a replacement for the bandpass filter described in chapter 3.1, then a similar effect can be achieved.

When combined with an appropriate longpass filter, a special kind of bandpass filter can also be generated.

Influence of the lighting angle

Wavelengths

Optical filters

Strobe vs. continuous

Fluorescence applications

Lighting systems for the reading and verification of codes

Lighting technology for shape-from-shading

## 3.3 Other optical filters

### 2. Longpass filters

In contrast to shortpass filters, longpass filters transmit wavelengths above the threshold wavelength. As with shortpass filters, longpass filters can be utilised to separate wavelengths from one another.

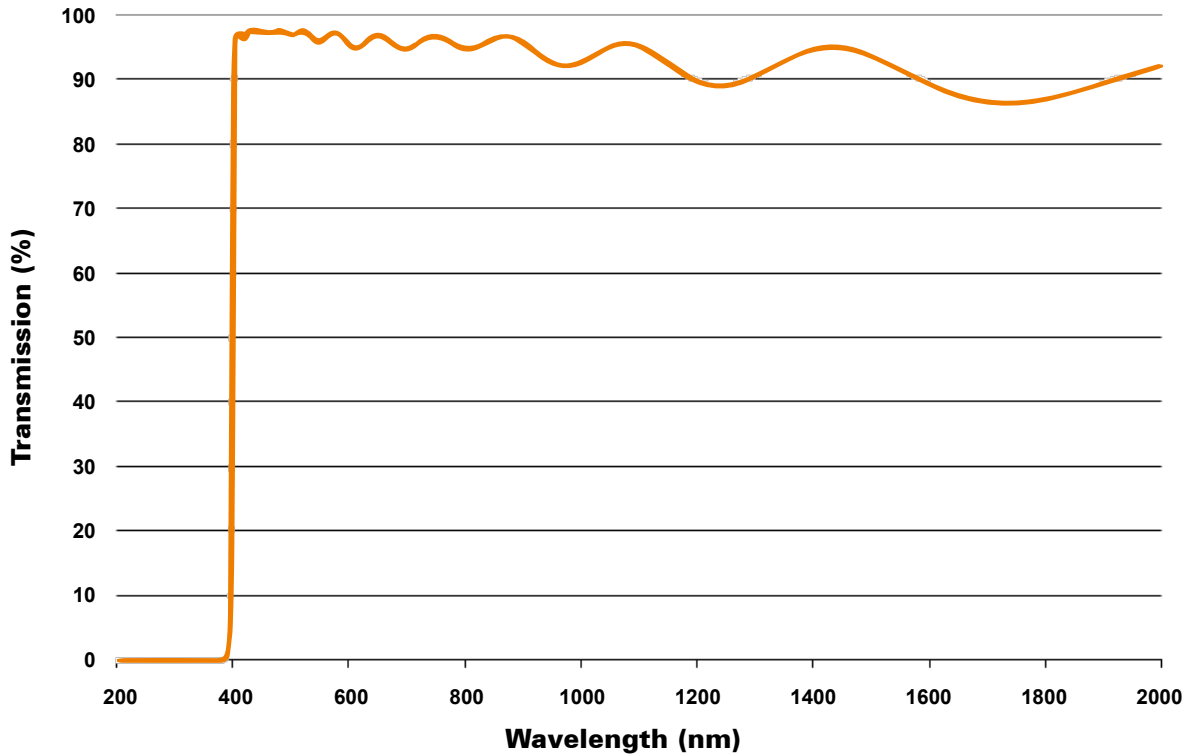

In fluorescence applications, for example, longpass filters can be placed in front of the lens, so as to attenuate the excitation wavelengths and thereby increase image contrast. For more information, see chapter 5.

Influence of the lighting angle

Wavelengths

Optical filters

Strobe vs. continuous

Fluorescence applications

Lighting systems for the reading and verification of codes

Lighting technology for shape-from-shading

## 3.3 Other optical filters

### 3. Colour filters

Colour filters are often used in conjunction with monochrome cameras. They are useful tools for increasing image contrast and separating, enhancing or suppressing certain colours. Colour filters are bandpass filters that transmit a specific colour band. If a red colour filter is used, for example, then red light is transmitted while other wavelengths are attenuated. Back in chapter 2.3, we looked at the interactions between coloured objects and visible light: an object reflects certain wavelengths and therefore appears coloured to the human eye. An object that we perceive as red therefore reflects the red portion of the light. Other wavelengths are instead absorbed. This particular mechanism can also be exploited when working with colour filters. If we use a colour filter in the same colour as the object, the object appears bright in the image. However, a colour filter in a different colour will make the object appear dark.

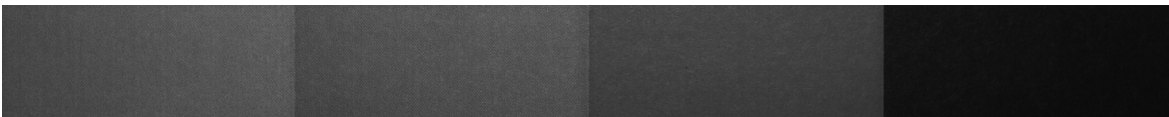
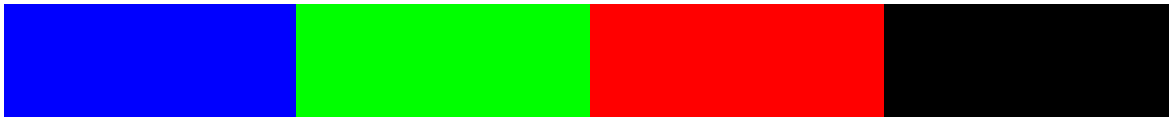

Imaged using white lighting with a monochrome camera

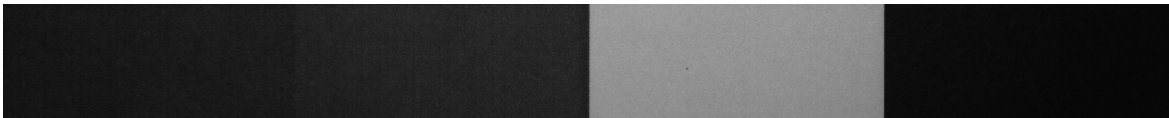

Red colour filter

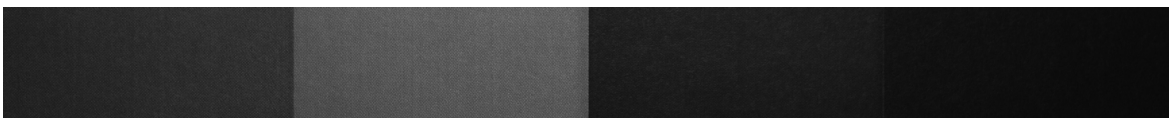

Green colour filter

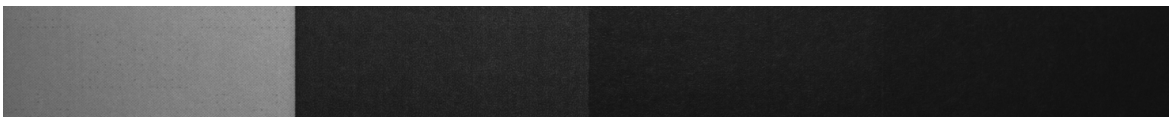

Blue colour filter

For details of the functionality provided by bandpass filters and their applications, see chapter 3.1.

### 4. Neutral-density filters

Neutral-density (ND) filters reduce the amount of incident light and are used to avoid overexposure effects in the image. These filters reduce light uniformly across the entire spectrum, and the use of a neutral-density filter has no effect on the representation of light colour or object colours.

Influence of the lighting angle

Wavelengths

Optical filters

Strobe vs. continuous

Fluorescence applications

Lighting systems for the reading and verification of codes

Lighting technology for shape-from-shading



## 4. Strobe vs. continuous

As well as selecting the optimal type of lighting, wavelength and filter, additional factors can have a fundamental influence on solutions for an image processing task. Once you have identified a suitable type of lighting, it is therefore worth spending some time considering the various operating modes. Within the industry, a huge variety of terms and jargon is used to describe these modes. Choosing the right mode is also often made more difficult by the occasionally loose use of such terminology. Strobe, flash, pulse, switched and continuous lighting are just some of the many terms used in this context.

In this fourth chapter of the LUMIMAX<sup>®</sup> Knowledge Base, we therefore want to concentrate on talking about the three fundamental modes used in Machine Vision.

- Continuous operation
- Switch operation
- Strobe operation

We will also define these terms, clarify the differences, and provide details of the pros and cons and typical applications for each mode.

### 4.1 Continuous and switch operation

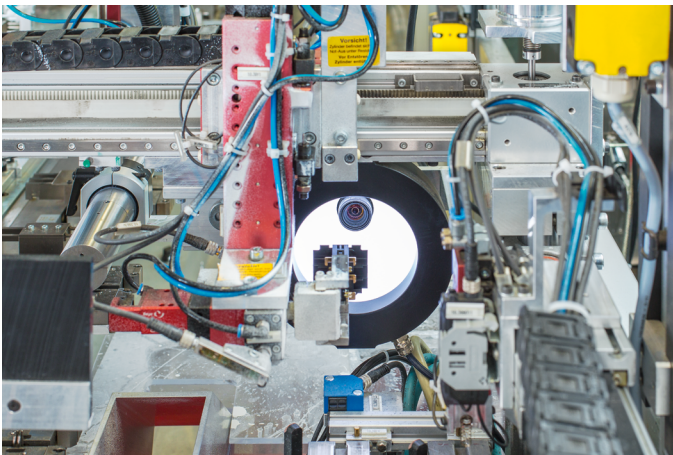

Verification system with LUMIMAX<sup>®</sup> Dome Lighting in a production line of Siemens in Amberg

Pulse or switched lighting solutions are also operated with nominal current, and therefore provide the same level of brightness as continuous lighting. Using fast, opto-isolated PLC and TTL switch inputs, however, these lighting systems can be switched on at the moment of image acquisition and switched off after the image is taken. The primary advantage to using switch operation is extending the service life of the LEDs: shortening the LED duty cycle can decisively lengthen the useful life of these parts. Compared to a continuous lighting system, a system operated for only half of the power-on time can achieve a service life that is twice as long.

Pulse or switch operation is itself often confused with strobe operation. In strobe operation, however, the LEDs are powered on for an extremely short period of time but at a much higher level of light output. This can solve problems that arise due to extraneous light or motion blur. The special features, pros and cons, and typical applications for strobe lighting will be discussed in chapter 4.2 of this Knowledge Base.

Influence of the lighting angle

Wavelengths

Optical filters

Strobe vs. continuous

Fluorescence applications

Lighting systems for the reading and verification of codes

Lighting technology for shape-from-shading

## 4.2 Strobe lighting

Any hobbyist photographer will be familiar with the use of a flash. But flash is not only a useful form of lighting for SLRs, digital cameras or phone cameras. Particularly in an industrial context, flash is a topic that is rapidly growing in popularity.

For industrial Machine Vision applications, however, flash units and integrated camera strobe lighting is not used. Instead, the forms of lighting used are exactly those discussed in chapter 1. These lighting systems are equipped with a specialised – and typically integrated – strobe controller capable of ‘flashing’ the system’s LEDs rapidly, precisely and with high-intensity output. When flashed, the LEDs are operated at a very high current. In this way, the brightness can be increased by a factor of up to 25 compared to continuous and pulsed lighting. Nor is strobe lighting merely orders of magnitude brighter: when the trigger signal is sent, the maximum light output of the lighting system is available within a period of time measurable in single-digit microseconds. This fast availability in conjunction with the enormous light output triggered means a very short exposure time can be set on the camera. The exposure time is therefore set to the flash duration and lies between 10 and 750  $\mu\text{s}$ . Thanks to the extremely short exposure time, the following problematic effects can be minimised.

### 1. Motion blur

The use of robots or conveyor belts to improve both productivity and throughput times always means one thing: accelerating motion within the process. Nor should the Machine Vision system act as a brake on this process speed. To ensure this doesn’t happen, the best approach is to acquire and analyse the image without interrupting the process. But can you guess the maximum exposure time possible if your object is moving at 0.5 m/s and you must also ensure that image blur does not exceed 2 pixels? Exactly 100  $\mu\text{s}$ .

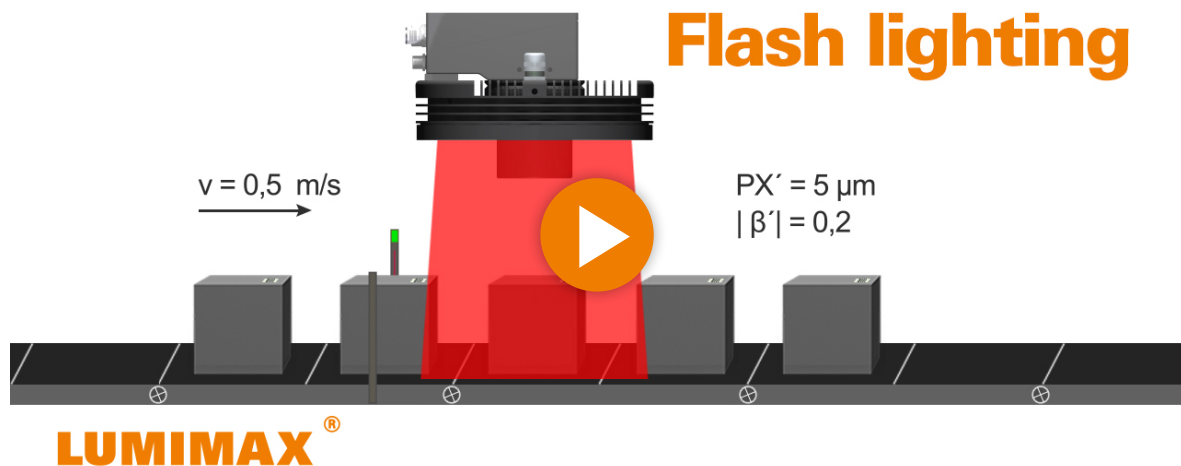

 Video can be viewed from  
<https://www.iim-ag.com/en/lumimax/useful-facts/videos/videotoflashlighting.html>

This would be inconceivable with continuous or pulsed lighting: their luminous intensity is simply too low to light the object properly. The switch-on delay for pulsed lighting is also much too long.

With strobe lighting, however, the maximum light output is available within 5  $\mu\text{s}$  and a vast amount of light is provided. As has been mentioned above, very short exposure times are therefore not a problem at all. The moving object can simply be ‘frozen’ in place (see video on page 29). For the human eye – and the camera – the moving object seems to come to a complete stop, and image analysis is now simple to perform.

Influence of the lighting angle

Wavelengths

Optical filters

Strobe vs. continuous

Fluorescence applications

Lighting systems for the reading and verification of codes

Lighting technology for shape-from-shading

## 4.2 Strobe lighting

### 2. Extraneous light

With short exposure times and the very high luminous intensity supplied by strobe lighting, extraneous light can also be completely suppressed. With an exposure time of no more than 750  $\mu$ s, even light from a window located right next to the camera or other light source will not be picked up and will therefore have no effect on the final test object image. This hugely increases the reliability of the analysis. In large, spacious factory buildings in particular, this means not having to worry about environmental conditions or ambient light disrupting camera-based inspection systems.

### 3. Stray light

Interestingly, the human eye perceives strobe lighting as less distracting than pulse lighting. While this may not seem entirely logical at first glance, take a look at the following video:

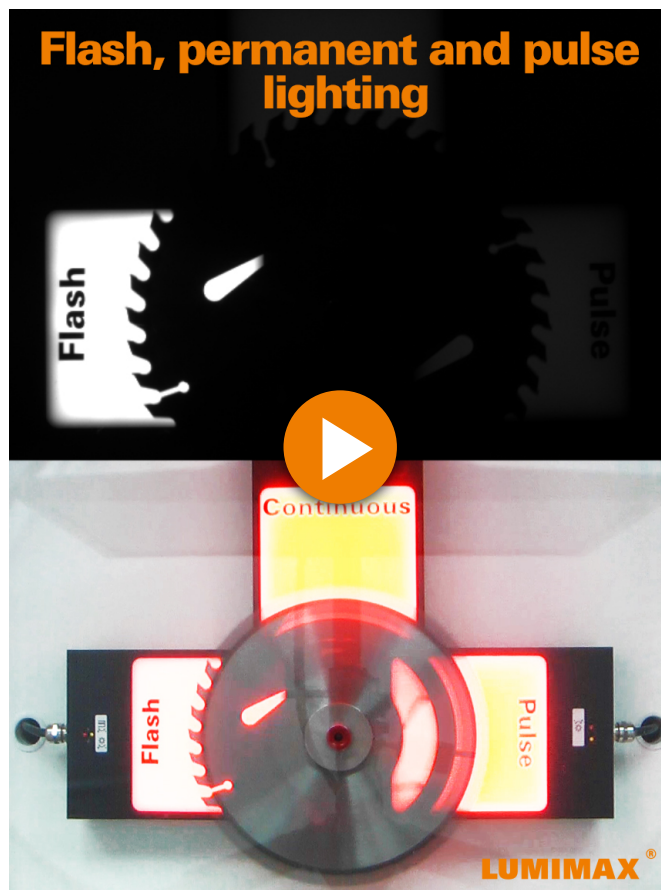

Video can be viewed from <https://www.iim-ag.com/en/lumimax/useful-facts/videos/video-flash-demonstrator.html>

In the lower image, the strobe lighting seems significantly darker than the pulse lighting. Even though the flash is actually much brighter – as can be seen on the camera image in the video. The effect stems from the fact that our eyes cannot see the short, rapid light flashes at their full intensity. Accordingly, the lighting is perceived as less distracting.

In the next chapter, we will use a number of examples to illustrate the advantages and typical applications for the various modes – with a special focus on strobe lighting.

Influence of the lighting angle

Wavelengths

Optical filters

Strobe vs. continuous

Fluorescence applications

Lighting systems for the reading and verification of codes

Lighting technology for shape-from-shading

## 4.3 Benefits of strobe lighting for industrial applications

In chapters 4.1 and 4.2, we introduced you to the properties of continuous, pulse and strobe lighting systems. If we now directly compare switch operation with strobe mode, we can identify the following key differences:

### ■ Pulse delay

In switch operation, the system's switch-on delay is about 5 ms. In contrast, strobe lighting responds extremely quickly to the trigger signal and can provide its full level of brightness after just 3 to 5  $\mu$ s.

### ■ Light intensity

In the very short time it is activated, strobe lighting supplies a luminous intensity as much as 25 times higher than that from continuous and pulsed lighting.

### ■ Duty cycle

While strobe lighting is switched on for a preconfigured period ranging from 10 to 750  $\mu$ s, the duty cycle of a pulsed lighting system depends on the length of the trigger signal. The pulse lighting system stays activated while the trigger signal is present.

Comparison of pulse and strobe mode lighting

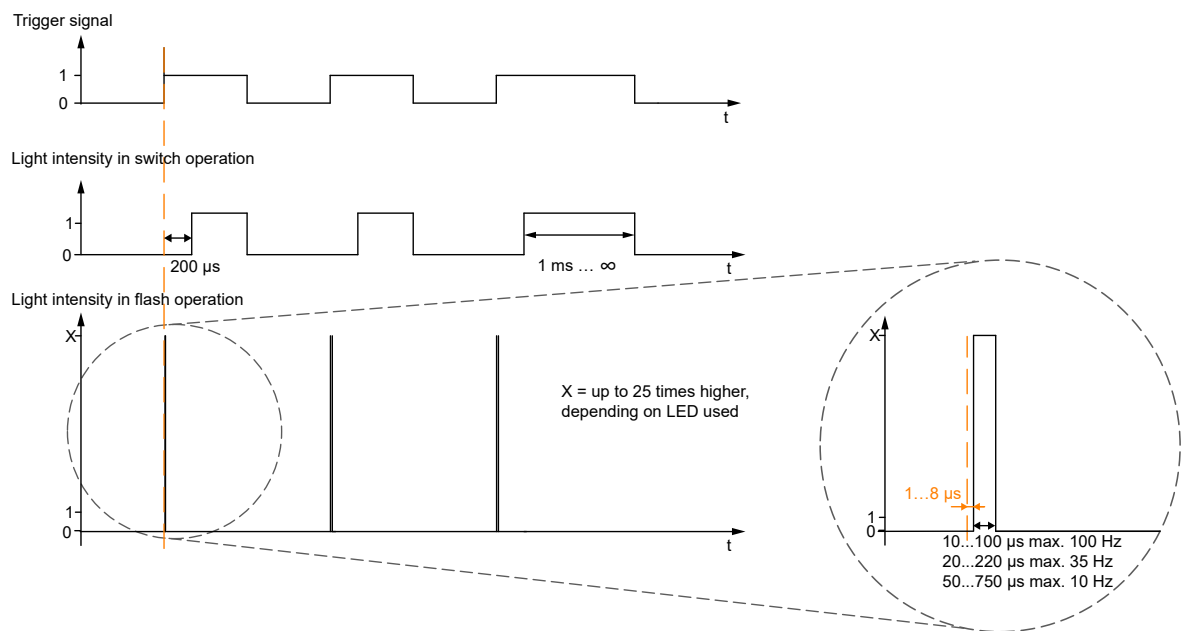

Influence of the lighting angle

Wavelengths

Optical filters

Strobe vs. continuous

Fluorescence applications

Lighting systems for the reading and verification of codes

Lighting technology for shape-from-shading

## 4.3 Benefits of strobe lighting for industrial applications

As a result of the properties described, the use of strobe lighting offers a number of key advantages when deployed in industrial processes. The time and cost savings achieved by using in-process inspections are particularly significant: in food and beverage production in particular, ultra high-speed processes with between 30 and even 100 product tests/second are by no means unusual. These processes simply cannot be stopped to perform QA work.

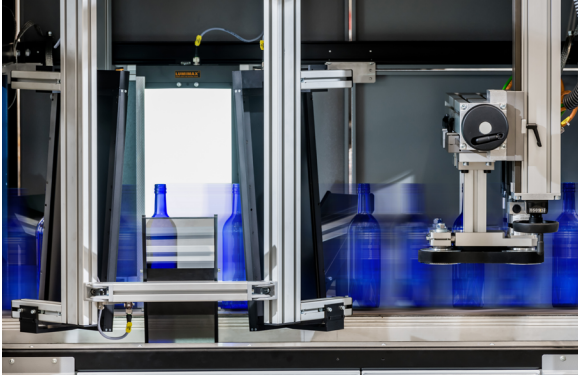

A typical industrial bottle filling plant

One example: During the inspection of glass products a fully automatic alignment system positions up to 500 glass containers perfectly every minute. Quality control and transportation are two stages in one smooth, continuous process. Because of this rapid motion, a pulse or static (continuous) lighting system would simply be unable to acquire a sharp image. The exposure time would be so long that the bottle would move an appreciable distance during the image recording, generating motion blur in the camera image. By using a strobe lighting system, a shorter exposure time can be used to capture an image at the same level of brightness. The bottle moves a much shorter distance in just 100  $\mu$ s. In the

camera image, the bottle therefore seems motionless and analysing the image for the required features is easily possible. If a continuous or pulse lighting system were used for such rapid processes, the bottle would have to be stopped to acquire the image. This kind of stop/start production line increases both handling work and wear, however, while capping production capacity and therefore nullifying the system's cost-effectiveness.

In pharmaceuticals, inspections are no longer used merely for quality assurance and improvement. Here, Machine Vision is increasingly used as a safeguard against product piracy. For example, in low- and middle-income countries, an estimated 1 in 10 medical products is substandard or counterfeit. To ensure these products cannot end up on the market in the first place, traceability legislation has now been tightened. Coding is now required not merely for the primary packaging and overpack used for drug products. In addition, codes must now also be placed on secondary and tertiary packaging. This extra check is naturally an inconvenience for the well-oiled, functional and – most importantly – fast packaging processes already in use. To keep delays here to the absolute minimum, products are inspected on the conveyor belt. Without strobe lighting to minimise potential motion blur, this would be impossible without reducing process throughput time.



Packaging inspection in the pharmaceutical industry

In terms of cost-effectiveness, strobe lighting also scores points by offering a longer service life than continuous lighting systems. The clock frequency, duty cycle and intensity all have a major influence on the operating temperature of the lighting system.

Influence of the lighting angle

Wavelengths

Optical filters

Strobe vs. continuous

Fluorescence applications

Lighting systems for the reading and verification of codes

Lighting technology for shape-from-shading

\* Quelle: <https://www.who.int/news-room/fact-sheets/detail/substandard-and-falsified-medical-products>

## 4.3 Benefits of strobe lighting for industrial applications

Influence of the lighting angle

Wavelengths

Optical filters

Strobe vs. continuous

Fluorescence applications

Lighting systems for the reading and verification of codes

Lighting technology for shape-from-shading



Even with powerful extraneous light sources such as large-scale factory building lighting, the camera image is not affected, thanks to flash.

In many such buildings, analysis is made difficult by large windows, overhead lighting and vehicles with rotating hazard or marking lights. The kinds of metallic, reflective and glossy objects frequently used in the automotive sector are particularly adept at reflecting most of this ambient light into the camera. These unstable lighting conditions are a problem for image analysis.

The irradiance\* of a strobe lighting system is orders of magnitude brighter than the intensity of ambient lighting. As a result, image analysis is affected neither by interference from factory lighting nor from sunlight streaming through a window.

Quality assurance inspections by a Machine Vision system are required not only on fully-automated production lines, however, but also in manual working environments. Inspection work should also be as straightforward as possible for workers. As the human eye cannot respond fast enough, the strobe light is perceived only as a weak 'spark' of light. This light is also significantly easier on the eye than continuous and pulsed lighting systems. The extreme reduction to these dazzling effects is therefore a major advantage for the cooperation between human workers and camera systems.

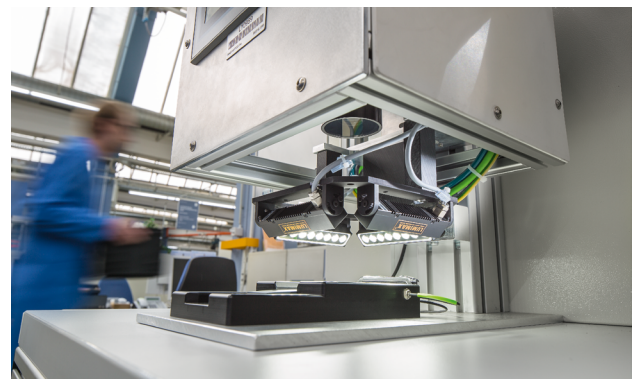

Verification station for manual quality control of Data Matrix codes

Now turn to the next chapter to learn about the aspects to consider when selecting and integrating strobe lighting.

\* For a precise definition of terms, see the Glossary on the last page of this Knowledge Base.

## 4.4 Key factors for strobe

If just a few points are borne in mind, the use and integration of a strobe lighting system is just as straightforward as installing a continuous or pulsed lighting source.

### 1. Synchronising flash with image acquisition

When integrating strobe lighting, the most important task is synchronising the strobe system and the image acquisition system. The lighting system generates a very high-energy flash of light in a moment of time no longer than 220  $\mu$ s. Capturing all of this light requires the precise coordination of image acquisition with the flash from the lighting system. One approach would simply be to set the camera's exposure time long enough to ensure that the flash occurs within this window of time. However, to do so would nullify all of the benefits related to eliminating ambient light and motion blur described in chapter 4.3. This is why it is important to match the camera exposure time both in terms of duration and the moment it is triggered to the strobe lighting: if the flash length is 220  $\mu$ s then the camera exposure time must also be 220  $\mu$ s.

To achieve this in practice, many camera makers offer a high-priority flash output interface. Assigning the flash output the highest priority ensures that the flash signal is always sent synchronously with image acquisition, and delays due to other processing tasks in the camera are not possible. If this priority is not set, the lighting system could receive its signal later than image acquisition. In this case, the image would not be sufficiently lit – if at all.



Using a T adapter cable to connect the camera and LUMIMAX<sup>®</sup> LED Ring Light

Unlike standard PLC outputs, a specialised flash output of this kind has also been optimised in terms of its signal quality. Both jitter\* and tolerances in trigger timing are minimised so that they have virtually no influence on the signal path.

Depending on the camera type, the lighting is then connected to the camera and the specific settings are configured in the controls.

If you have any queries about connecting LUMIMAX<sup>®</sup> LED Lighting to your camera system, please contact us for assistance.

\* For a precise definition of terms, see the Glossary on the last page of this Knowledge Base.

Influence of the lighting angle

Wavelengths

Optical filters

Strobe vs. continuous

Fluorescence applications

Lighting systems for the reading and verification of codes

Lighting technology for shape-from-shading

## 4.4 Key factors for strobe

### 2. Assessing motion blur from the speed of the test object and the length of the flash signal and exposure time

Motion blur in the final image depends both on the object (or conveyor belt) velocity  $v$  and the duration of the flash  $t$ . By inputting the maximum motion blur allowed in the image and the velocity, you can then calculate the maximum flash duration  $t_{\max}$ .

To do so, first calculate the permitted object displacement, i.e. the distance that your test object can move during image acquisition before exceeding the level of blur allowed in the image.

Example:

A printed code needs to be scanned on a drug product packaging. The product pack is moving at 0.5 m/s on a conveyor belt. The image scale is  $|\beta'|$  is 1:5. In the image sensor used  $PX'$ , the width of a pixel is 5  $\mu\text{m}$ . The maximum level of blur in the image is set at 2 pixels.

The maximum object displacement  $l_{\max}$  in the image is calculated as follows:

$$l_{\text{zul}} = \frac{\text{permissible blur} \cdot PX'}{|\beta'|} = \frac{2 \text{ Pixel} \cdot 5 \frac{\mu\text{m}}{\text{Pixel}}}{0,2} = 50 \mu\text{m}$$

By taking the maximum object displacement permitted and the object speed, the maximum flash duration  $t_{\max}$  can now be calculated.

$$t_{\max} = \frac{l}{v} = \frac{50 \mu\text{m}}{0,5 \frac{\mu\text{m}}{\mu\text{s}}} = 100 \mu\text{s}$$

Using an exposure time/flash duration of 100  $\mu\text{s}$  will therefore ensure that the object is not shifted by more than 2 pixels in the final image.

**Video: product inspection for fast-moving processes using a Machine Vision system**

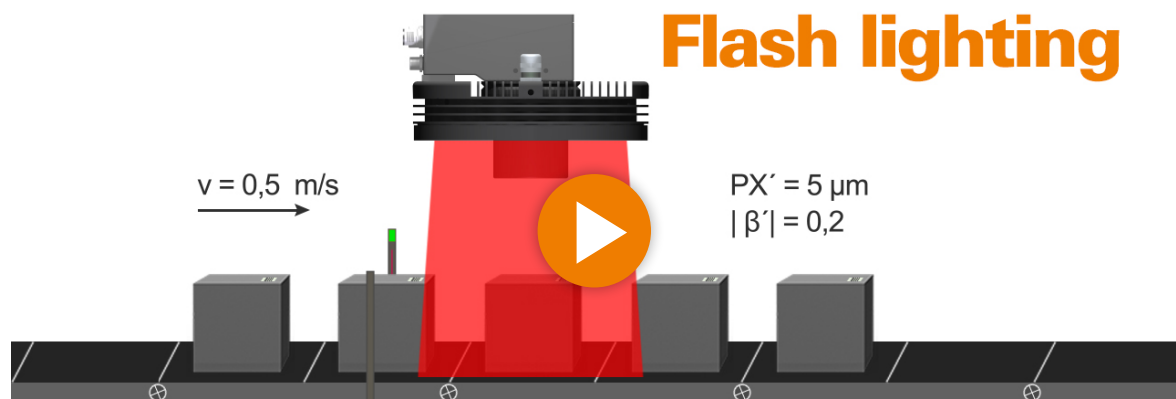

Video can be viewed from  
<https://www.iim-ag.com/en/lumimax/useful-facts/videos/videotoflashlighting.html>

Influence of the lighting angle

Wavelengths

Optical filters

Strobe vs. continuous

Fluorescence applications

Lighting systems for the reading and verification of codes

Lighting technology for shape-from-shading

## 4.4 Key factors for strobe

### 3. The interplay of irradiance and exposure time

Especially in lab work, continuous-mode lighting tends to be used first. If a decision is then made to switch to strobe lighting when integrating with the plant, the question then arises about the flash time  $t$  to set to achieve the right level of brightness. Assuming that all other settings remain the same – such as the photosensitivity of the sensor, the luminous transmission of the lens and the camera gain – then this can be calculated by using the factors of irradiance  $E(t)$  and grey level GL:

$$GW = \int E(t) dt$$

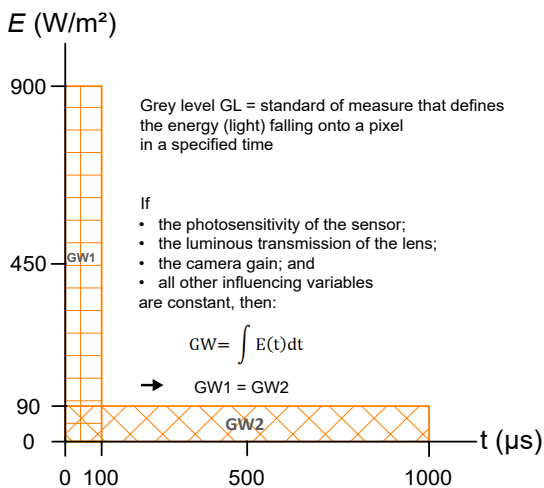

Grey level at various values for exposure time and irradiance

#### Example:

In continuous mode, a test object was lit for 2200  $\mu s$  with an irradiance of 90  $W/m^2$ .

In strobe mode, the identical test object is also to be imaged. The grey levels in the object image should match those obtained in continuous mode. To meet this specification, we need to calculate the factor by which the irradiance needs to be increased when operating in strobe mode.

If we assume an exposure time of 220  $\mu s$ , then we obtain the following ratio:

$$E_{\text{flash}} = \frac{t_{\text{continuous}}}{t_{\text{flash}}} = \frac{2200 \mu s}{220 \mu s} \rightarrow \text{factor } 10$$

The strobe lighting therefore needs to be ten times brighter than the continuous lighting. If this can be guaranteed, then use of a strobe lighting system is possible without having to compensate for a loss in image brightness.

If the three factors mentioned are considered when designing an appropriate strobe lighting system, this will simplify integration with the plant. In addition, almost all of the LUMIMAX<sup>®</sup> LED Strobe Lighting Systems have a special feature that also simplifies their installation into a machine setup – namely an integrated strobe controller. This guarantees the maximum level of safety and functionality, shortens integration time with the Machine Vision system and ensures no power losses due to long cables between controller and lighting. The integrated controller also saves space and cuts costs since there is no need to use an additional module.

Influence of the lighting angle

Wavelengths

Optical filters

Strobe vs. continuous

Fluorescence applications

Lighting systems for the reading and verification of codes

Lighting technology for shape-from-shading

## 4.4 Key factors for strobe

Influence of the lighting angle

Wavelengths

Optical filters

Strobe vs. continuous

Fluorescence applications

Lighting systems for the reading and verification of codes

Lighting technology for shape-from-shading



Mounting solutions with camera and lighting

The extensive range of optical, electrical and mechanical accessories for LUMIMAX® LED Lights also simplifies both modification work to suit customer-specific requirements and integration with the machine environment. These innovative solutions enable quick and easy integration of LUMIMAX® LED Lights within a small footprint. With the special T-adapter cable\*, the lighting can be connected directly to the camera system, from where it is then controlled. This saves on additional wiring effort while simplifying component commissioning. The adapter cable is located between the camera's electrical connection and the power supply. This is used to couple the lighting system directly into this signal flow, so it can use the camera both as its power supply and the trigger signal source. This reduces system design and installation work, ultimately achieving significant cost savings.

The LUMIMAX® Mounting Solutions enable the direct mounting of the High-Performance LUMIMAX® Area and Spot Lighting Systems to the camera series Cognex, Baumer, Keyence, SensoPart and Siemens. The mounting variations can be individually adapted and flexibly expanded, so as to ensure the exact adjustment of lighting angles and working distances. As an end result, the lighting, optics and camera form a single, compact unit.

\* Can be used for all LUMIMAX® Strobe Lighting with the exception of lighting systems requiring an external controller and the models LG3020FL, LGCB3020FL, LG4030FL, LGCB4030FL and LB500FL.





## 5. Fluorescence applications

UV lighting is always used in cases where materials require excitation in order to 'glow'. While the excitation wavelength will depend on the fluorescent medium used, it may be found anywhere within the complete spectrum – from ultraviolet to near infrared. Since industrial processes primarily involve the use of ultraviolet radiation, this part of our Knowledge Base focuses on applications using ultraviolet irradiation. Fluorescence applications are needed in a wide variety of industries.

### A brief overview of typical applications:

- Inspection of adhesives, paints, sealants and lubricants
- Inspection of safety features and markings as protection against fake and counterfeit goods
- Product labelling
- Track & Trace
- Analysis of residues/residual soiling
- Crack, cavity and defect inspection
- Forensic analyses

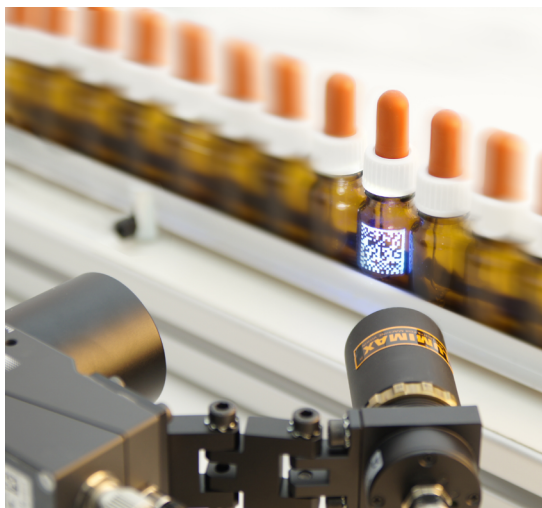

Track & Trace in the pharmaceutical industry

The 'glowing' described above is luminescence, the generation of light from matter. Luminescence is the optical radiation that occurs during the transition from a stimulated state to the basic state. A key distinction is made between fluorescence and phosphorescence.

- With **fluorescence**, a material emits light while being stimulated, i.e. it starts to glow on exposure to radiation at a certain wavelength. However, this glowing fades as soon as the irradiation ceases.
- **Phosphorescence** describes a similar effect, although the material also continues to glow after irradiation has ended. This 'afterglow' can last several hours – or may fade away after a few moments. The duration depends on irradiance and the phosphorescent material itself.



Cast part with fluorescent application under UV irradiation  
Left: fluorescence can easily be seen by the human eye



Right: same setting as left but monochrome camera image

Influence of the lighting angle

Wavelengths

Optical filters

Strobe vs. continuous

Fluorescence applications

Lighting systems for the reading and verification of codes

Lighting technology for shape-from-shading

## 5. Fluorescence applications

While the inspection of phosphorescent materials can be performed without using any special filters, one recurring problem with fluorescent materials is that the light emitted has less energy than that the light absorbed. Since fluorescence is easily visible to the human eye, this leads to the miscomprehension that the glow will also be clearly imaged by the camera. The camera is much more sensitive in the ultraviolet spectrum, however, while the human eye barely registers UV radiation at all. In reality, the glow is actually much weaker than the luminous intensity of the UV lighting. In the camera image, the UV light outshines the fluorescence of the stimulated material. Often, the contrast is too weak to ensure a reliable process inspection.

Image acquisition without lens and lighting filter

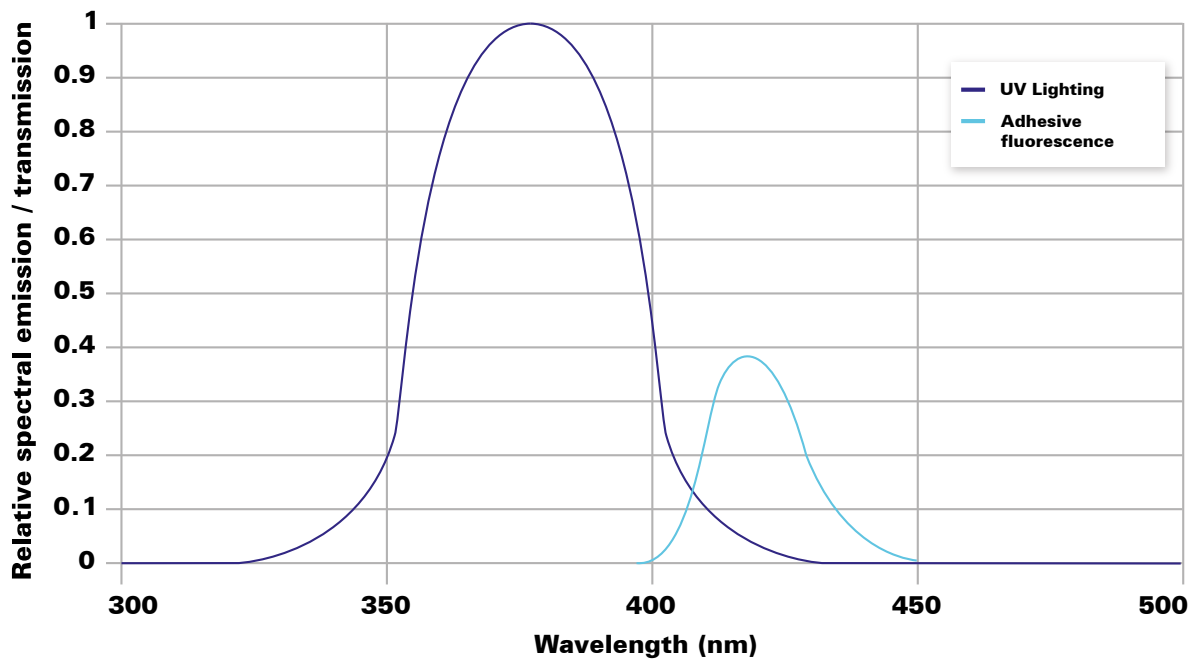
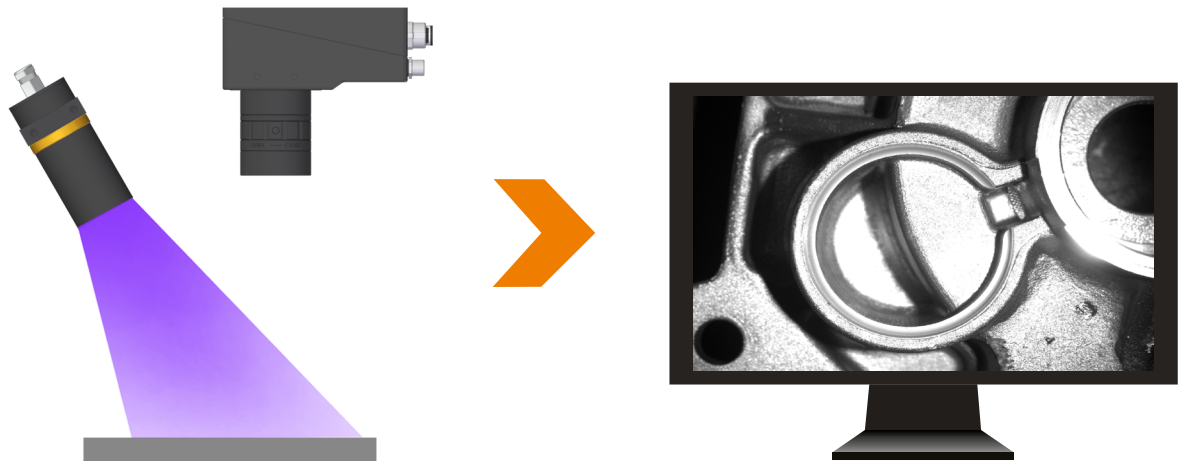

Influence of the lighting angle

Wavelengths

Optical filters

Strobe vs. continuous

Fluorescence applications

Lighting systems for the reading and verification of codes

Lighting technology for shape-from-shading

## 5. Fluorescence applications

To reliably solve these kinds of difficult tasks, the use of a high-performance LED lighting system combined with a specialised filter is recommended.

The most important factor here is the choice of a suitable lens filter. Ideally, a bandpass filter will be used that is precisely matched to the wavelength of the fluorescent material. If the material glows at a wavelength of 430 nm, for example, a filter is selected that lets exactly this wavelength pass, while rejecting all other wavelengths. This not only blocks ambient light but also the vast majority of the required UV radiation. However, since this is not always possible – as in the case of white fluorescence – the use of a longpass filter can also be considered. This is chosen to block all stray light from the UV lighting system.

Image acquisition with lens filter but without lighting filter

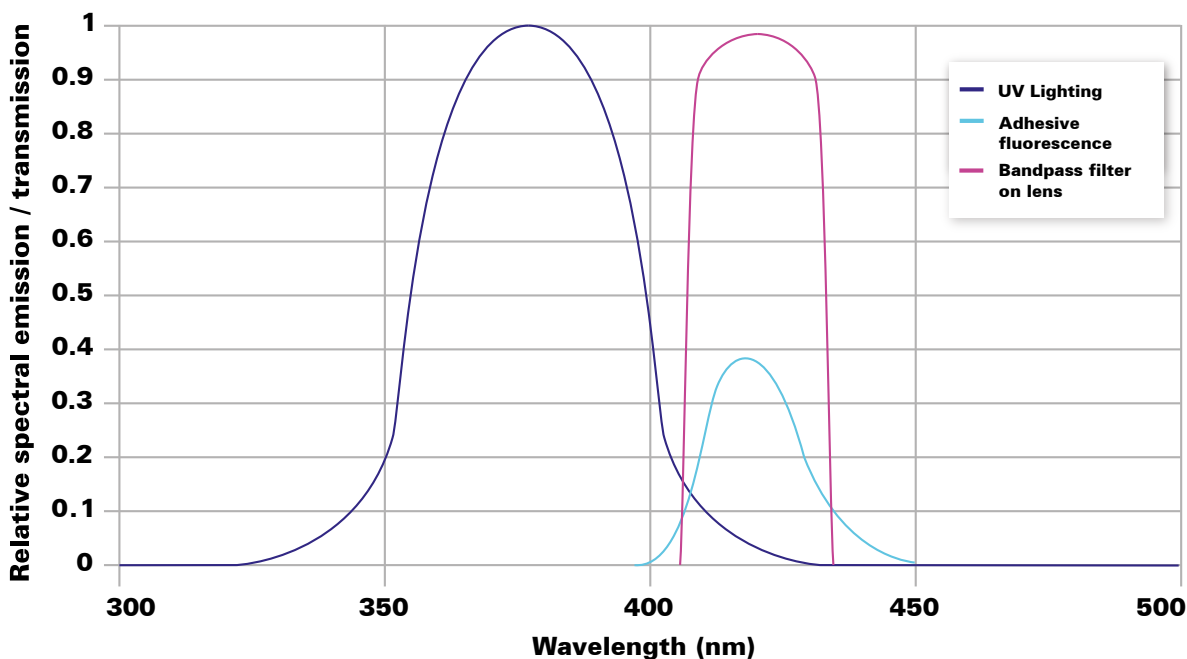

Influence of the lighting angle

Wavelengths

Optical filters

Strobe vs. continuous

Fluorescence applications

Lighting systems for the reading and verification of codes

Lighting technology for shape-from-shading

## 5. Fluorescence applications

UV LEDs emit a very broad spectrum of light, a portion of which contains visible blue light. Blue or white fluorescence in particular makes the choice of a lens filter more difficult, since the spectra of the light source and the fluorescence are very close together. Here, specialised lighting filters are used, which transmit only the UV radiation actually required while attenuating all of the remaining light.

Image acquisition with lens filter and lighting filter

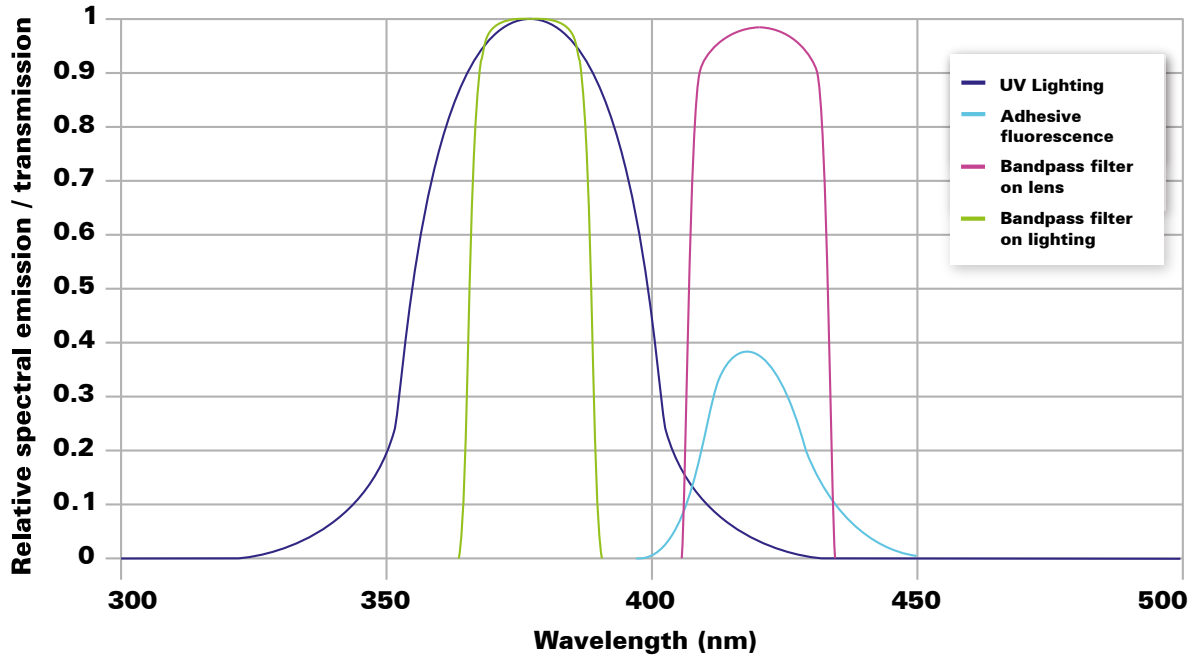

With the use of high-performance LED lighting combined with a perfectly-matched pair of lens and lighting filters, it is possible to entirely eliminate both the light from the lighting system and the distracting light from the environment. As a result, fluorescent features appear as brightly-lit areas in the camera image on a dark background.

Influence of the lighting angle

Wavelengths

Optical filters

Strobe vs. continuous

Fluorescence applications

Lighting systems for the reading and verification of codes

Lighting technology for shape-from-shading





Chapter 1 – Influence of the lighting angle

Chapter 2 – Wavelengths

Chapter 3 – Optical filters

Chapter 4 – Strobe vs. continuous

Chapter 5 – Fluorescence applications

**Chapter 6 – Lighting systems for the  
standards-compliant reading and verification of codes**

Chapter 7 – Lighting technology for shape-from-shading applications

## 6. Lighting systems for the standards-compliant reading (validation) and verification of codes

*In tomorrow's state-of-the-art, fully automated facilities, products control their own manufacturing process. With the aid of machine-readable product labelling, innovative tracking procedures enable the optimisation of manufacturing processes, machine capacity utilisation, costs and product quality. Yet the vision of 'Industry 4.0' depends crucially on the communication between product and machine. Only a high-quality product code can guarantee a smooth, error-free flow of information. Thanks to Machine Vision-based code verification, potential problems are resolved before they even occur.*

### Reading

Simple code reading

### Standardised reading (validation or grading)

Objective evaluation of code quality without strict adherence to standards

### Verification

Checking of code quality using standardised procedures and parameters according to international standards

In a 'smart' factory, the products communicate directly with the machinery. Via its product code, the product itself tells the system which step must be performed next. And thanks to the information obtained, the complete production process can be tracked for each individual product. This ensures optimal process flow control.

Nor does the versatility of product label applications stop at process optimisation and quality inspection: a Data Matrix Code can also be used to provide the end user with all of the information that they require. Product traceability is another area that is now increasingly important – such as for combating counterfeit pharmaceutical products, for example.

### Direct Part Marking (DPM) procedure

- Dot peen marker
- Laser marker
- Scribe marker
- Electrolytic marker (etching)
- Inkjet

Yet the proper functioning of these kinds of systems is dependent on the reliability of product code scanning. Direct Part Marking (DPM) codes are especially durable and long-lasting. With DPM technology, the machine-readable code is marked directly and permanently on the product. Additional product labels are no longer necessary.

The quality of the code is then verified using standardised procedures: ideally, this takes place in the plant directly after marking and then whenever the mark could be later affected. Trend analysis is used to ensure that the marking process proceeds without errors at all times. If the quality of a marking system starts to decline, this problem can be caught early before the mark actually becomes illegible. Right from the outset, this avoids time-consuming rework – or scrapping, in the worst case. The verification procedure guarantees the 100% legibility of the code throughout the entire production process – and beyond. To execute the reading and verification process in line with the standards, the lighting situation is determined alongside camera and software factors.

A standard-compliant set-up usually requires a 90° viewing angle for the camera and thus the camera must be positioned vertically to the test piece. Changes to this viewing angle would cause axial unevenness in the code and thus lead to a poor result in the quality assessment.



Data Matrix code - code correctly imaged at a 90° viewing angle



code skewed by a change to the viewing angle

Influence of the lighting angle

Wavelengths

Optical filters

Strobe vs. continuous

Fluorescence applications

Lighting systems for the reading and verification of codes

Lighting technology for shape-from-shading

## 6. Lighting systems for the standards-compliant reading (validation) and verification of codes

Influence of the lighting angle

### The standards

The standards ISO/IEC 15415:2011/ 15416:2016 and ISO/IEC 29158:2020 are particularly interesting when it comes to the standard-compliant reading and verification of codes.

### ISO/IEC 15415:2011/ 15416:2016

ISO standard 15415:2011/ 15416:2016 relates to printed codes on labels and similar.

### ISO/IEC 29158:2020

In contrast, the DPM standard ISO 29158 is used for direct part marking (DPM) and, for instance, also applies to lasered and needled codes on various surfaces.

Wavelengths

Optical filters

Strobe vs. continuous

Fluorescence applications

Lighting systems for the reading and verification of codes

Lighting technology for shape-from-shading

The framework for verifying DPM matrix codes is provided by the standard ISO/IEC 29158:2020 (AIM DPM). For printed codes, the standard ISO/IEC 15415:2011/ 15416:2016 is referenced.

Apart from verification criteria and procedures, the standards also define the exact parameters for image scanning. This ensures that the code is not compromised by the components selected. According, the design of the Machine Vision system is not based solely on the part substrate but also on the specific characteristics of the marking or print system utilised.

When selecting a Machine Vision system, the lighting system has an especially important role to play.

Depending on the standard applied, three separate lighting arrangements are permitted: an arrangement of 1, 2 or 4 lighting systems at a 30° or 45° angle. For very shiny or reflective surfaces, a coaxial lighting system or even a dome lighting system can also be deployed.

### ISO/IEC 15415:2011/ 15416:2016 for printed codes

The ISO/IEC 15415:2011/ 15416:2016 standard defines three lighting versions for the standards-compliant reading and verification of codes, whereby four lights arranged in a square at an angle of 45° to the surface are defined as standard lighting. Depending on the application, however, the angle can also be reduced to 30° to the surface.

Under special conditions – such as for glossy and reflective surfaces – diffuse lighting is also permitted, which is then positioned once again at a 90° angle to the object. The light field is thus parallel to the surface. Coaxial reflected lighting is used for these applications. With this type of lighting, a diffuse, homogeneous light source is mounted over a semi-transparent reflector directly in the lens beam path. This provides very homogeneous, shadow-free lighting for the object.

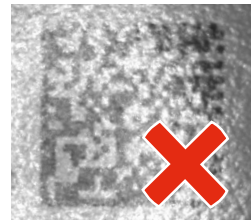

Data Matrix code on a cardboard overpack – directional 45° setup from 4 directions

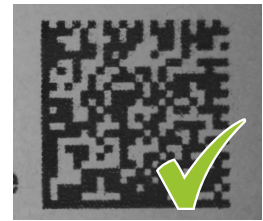

diffuse coaxial reflected lighting

### ISO/IEC 29158:2020 for direct part mark codes

In contrast to ISO/IEC 15415:2011/ 15416:2016, ISO/IEC 29158:2020 permits additional lighting setups for directly marked codes. Among other things, the standard setup of four lights arranged in a square is expanded to include variants with two lights opposite one another and a single light. The angle of 45° to the surface can be changed depending on the application, e.g. to 30°.

In addition, the standard defines the tilted coaxial lighting and camera setup (TCL) as a further standard-compliant setup. The lighting and a camera suitable for this setup are arranged at an angle other than 90°, for example 30°, 45° or 60°. The setup can be implemented with both coaxial and ring lighting.

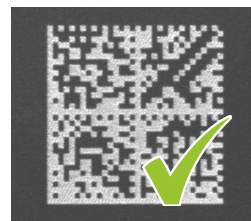

Lasered code on plastic surface

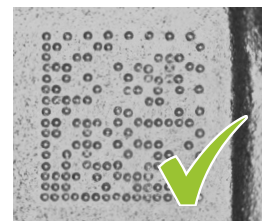

Needled code on cast metal surface

## 6. Lighting systems for the standards-compliant reading (validation) and verification of codes

Depending on the material and shape of the test piece, a suitable version can be determined here:

- **plane, matt and rough surfaces:** four-sided lighting arrangement
- **curved and rotationally symmetrical surfaces:** two- or one-sided lighting arrangement
- **glossy and reflective surfaces:** Coaxial or dome lighting
- **glossy surfaces with a complex structure:** Dome lighting

### Standard-complaint set-up

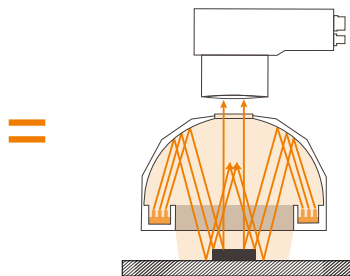

#### Off-axis diffuse „D“

Norm ISO/IEC 29158:2020

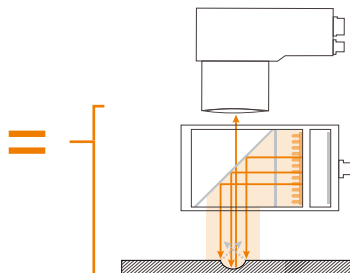
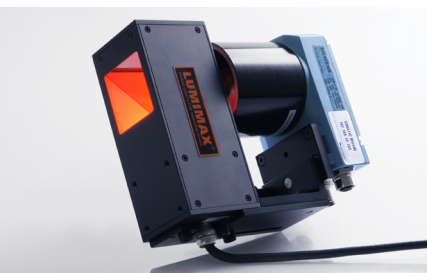

#### On-axis diffuse 90° „90“

Norm ISO/IEC 29158:2020

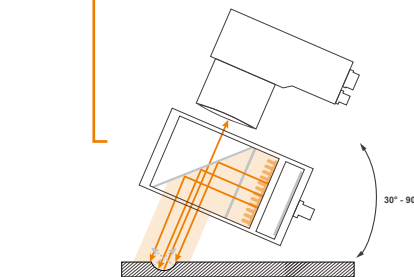

#### Tilted coaxial lighting and camera (TCL)\*

Norm ISO/IEC 29158:2020

- 30° „30CS“
- 45° „45CS“
- 60° „60CS“

\* Notes: special hardware/ software required;  
Ring lights suitable for TCL

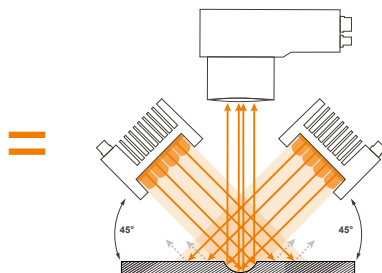

#### Medium angle 45° / Low angle 30°

Norm ISO/IEC 15415:2011/  
15416:2016:

- four direction: „45Q“, „30Q“

Norm ISO/IEC 29158:2020:

- four direction: „30Q“
- two direction: „30T“
- one direction: „30S“

Influence of the lighting angle

Wavelengths

Optical filters

Strobe vs. continuous

Fluorescence applications

Lighting systems for the reading and verification of codes

Lighting technology for shape-from-shading

## 6. Lighting systems for the standards-compliant reading (validation) and verification of codes

### Simple integration

The lighting system and its setup for the test object is an important factor for the standards-compliant reading and verification of codes. To ensure the standards-compliant, reproducible and simple integration of lighting into the plant environment, customers can rely on the LUMIMAX<sup>®</sup> Mounting Systems.

One interesting option for mounting a coaxial or dome lighting system is offered by the LUMIMAX<sup>®</sup> Verification Adapter. This is used not only to mount the lighting directly on the camera system but can also pivot the lighting in and out in a predefined manner. This permits the optimal configuration of the camera, optics and lighting, and the protective tube can be mounted at the end, without any settings needing to be changed. To do so, the lighting is simply pivoted out and the protective tube is easily affixed. The lighting is then pivoted back into the exact position as configured earlier. The LUMIMAX<sup>®</sup> Verification Adapter also ensures a reproducible setup across all reading units.

An innovative mounting system is also available for the LUMIMAX<sup>®</sup> Miniature Bar Lights in the LSB series. These can be installed as a four-, two- and single-sided lighting system within a mounting bracket. To ensure the Bar Lighting System has a standards-compliant 45° and 30° angle to the surface, mounting points are already marked with which a standards-compliant setup can be guaranteed. The incident angle can also be altered between 0° and 90° in steps of 7.5°. This Mounting System can also be attached to the LUMIMAX<sup>®</sup> Verification Adapter, so as to ensure the lighting system can be simply pivoted into and out of a predefined, standards-compliant position.

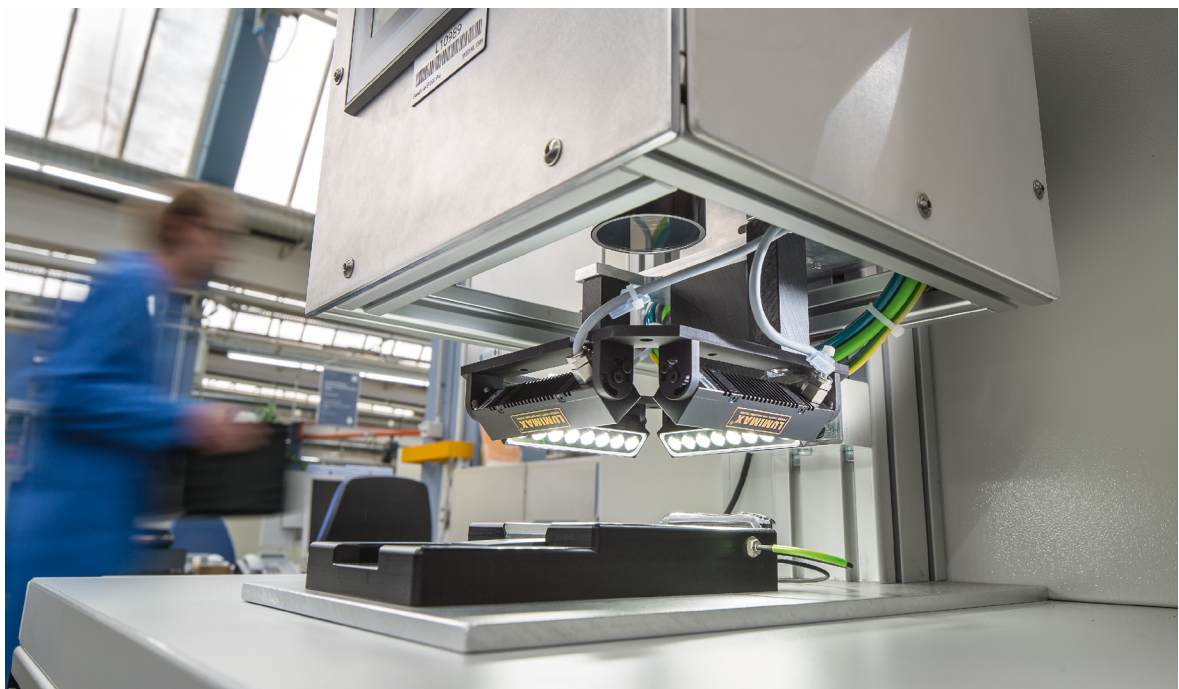

Verification station for manual quality control of Data Matrix codes

Influence of the lighting angle

Wavelengths

Optical filters

Strobe vs. continuous

Fluorescence applications

Lighting systems for the reading and verification of codes

Lighting technology for shape-from-shading





## 7. Lighting technology for shape-from-shading applications

The reliable automated inspection of problematic surfaces is a technical tour de force for Machine Vision. This includes both the detection of surface defects as well as the identification of test criteria. Yet what a human can often make out merely by glancing at an object presents a Machine Vision system with a monumental challenge. Identifying minuscule defects and characteristics on a surface is a demanding enough task on its own, but is made much more difficult by a diversity of shapes, textures, colours, surface variations and reflection properties. Where conventional Machine Vision starts to meet its match is where shape-from-shading takes over: the perfect symbiosis of a Machine Vision system and lighting.

Shape-from-shading is based on the demarcation of texture and topography on the test object. This is achieved by examining the region to be tested with multiple images captured from a variety of directions. Each image faithfully captures the orientation-dependent shading of the surface. These areas of light and shade present us with the height and depth data that we need for further processing. The individual images are then fed into an aggregate computation whose output supplies the topographic information for the test object. This creates an almost three-dimensional representation of the surface of interest.

In a conventionally acquired image, colour differences, changes in brightness, textural features and surface blemishes such as rust will work to alter the evaluation. With shape-from-shading, these disturbance factors are rendered virtually invisible – leaving only the surface's 3D information. Even defects or characteristics a few microns high or deep become visible. The output image can be evaluated quickly and reliably with standard Machine Vision algorithms such as OCR detection or edge detection software.



Video can be viewed from: <https://www.iim-ag.com/en/lumimax/useful-facts/videos/video-shape-from-shading.html>

### Typical applications for shape-from-shading include:

- Surface inspections on highly reflective backgrounds
- Checking stamped numbers, embossing and engravings
- Reading dot-peened or laser-cut characters and codes
- Edge inspection
- Assembly inspection – e.g. when joining various plastic pieces
- Type and position checks

By separating topographical and colour information, for example, Braille dots on a printed medicine packaging can be clearly distinguished from a multi-coloured background and therefore checked for correctness.



Conventional image capture using LED ring lighting

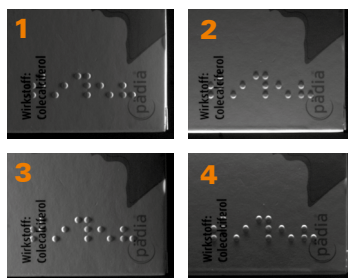

Shape-from-shading image capture using 4 miniature bars from the LSB series

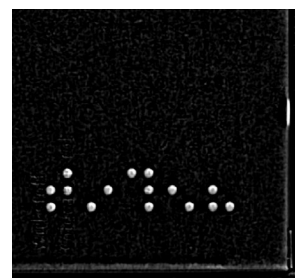

Result: the Braille dots are clearly discernible against the background

Influence of the lighting angle

Wavelengths

Optical filters

Strobe vs. continuous

Fluorescence applications

Lighting systems for the reading and verification of codes

Lighting technology for shape-from-shading

## 7. Lighting technology for shape-from-shading applications

But even more challenging surfaces, such as cast parts and highly reflective or polished metals, can also be represented by shape-from-shading so that features such as embossing or stamped numbers can be reliably evaluated.

At the heart of the method lies a sophisticated Machine Vision algorithm. As the name shape-from-shading suggests, light and shade have a decisive role to play here – as they so often do in Machine Vision in general. Despite specialised software algorithms, lighting is and will remain one of the most important elements in producing an image. For this method in particular, which determines height and depth information by using a range of shadow images, the arrangement of the lighting to the camera and the test object is decisive to achieve an optimum result.



Suitable lighting for shape-from-shading applications: LUMIMAX<sup>®</sup> Miniature Bar Lights in four-sided mounting bracket

Various types of reflected-light setups can be deployed here. One precondition is that the lighting must consist of individual switchable segments around the test object. After considering the material, the surface properties and the size of the test object, plus the working distance, the following kinds of lighting are typically utilised:

- Bar lighting arranged in a square or rectangle
- Ring, dark field or dome lighting, as an array of switchable segments

Bar lighting is a very flexible option to choose. These systems can be arranged freely and adjusted easily as regards, positioning, distance and angle for the task in hand.

A lighting setup of this kind – consisting perhaps of 4 Mini Bar Lights from the LSB series – offers maximum flexibility while ensuring the lighting has a high luminous intensity. Thanks to the very flat beam angle, sharp shadows are thrown even by very small variations in the surface. If the features are hidden – such as inside a ring, for example – then the lighting can be raised up and also arranged at a steeper angle.

### Example: milled characters inside a metal part

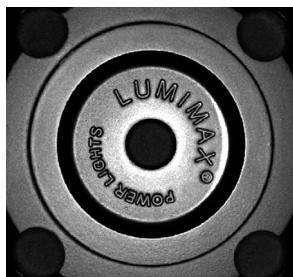

Conventional image capture using LED ring lighting

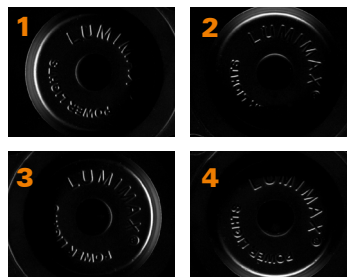

Shape-from-shading image capture using 4 Miniature Bars from the LSB series



Result: the milled characters are thrown into sharp relief

Some surfaces cannot be optimally lit with this kind of arrangement, however. Very shiny and reflective surfaces will mirror the butt joints between the edges of the individual bar lights. In these cases, having a contiguous lighting system is advantageous.

Influence of the lighting angle

Wavelengths

Optical filters

Strobe vs. continuous

Fluorescence applications

Lighting systems for the reading and verification of codes

Lighting technology for shape-from-shading

## 7. Lighting technology for shape-from-shading applications

A ring-shaped lighting system with 4 or more individually controllable segments, and which can be equipped with diffusers of various strengths depending on the reflexivity of the test surface, is a good alternative here. Dome lighting is another excellent choice for illuminating very shiny or reflective parts. Equally, the highly directional light offered by dark field lighting systems are ideal for surface variations with very little depth or height.

Due to the complexity of the topic and the difficulty of estimating potential results from the outset without conducting tests, the optimal lighting arrangement should be determined for each project in a Machine Vision laboratory. Not least because many Machine Vision problems can be resolved quickly and reliably only when the light is right.

Influence of the lighting angle

Wavelengths

Optical filters

Strobe vs. continuous

Fluorescence applications

Lighting systems for the reading and verification of codes

Lighting technology for shape-from-shading



## Glossary

### ■ **Black-body radiator**

A black body (also black-body radiator, perfectly black body) is an idealised source of thermal radiation. This black body is 'perfect' in the sense that it completely absorbs all incident electromagnetic radiation it encounters at any wavelength. Simultaneously, this body emits thermal radiation, whose intensity and spectral distribution is independent of the body's composition and surface, and which depends solely on the body's temperature. Assuming the area is the same, this body emits thermal radiation in every wavelength region more strongly than any real body at the same temperature. Such bodies serve both as a basis for theoretical research and as a reference for practical investigations of electromagnetic radiation. (Source: [www.wikipedia.de](http://www.wikipedia.de), 2015)

### ■ **Brewster's angle**

Brewster's angle – also 'polarisation angle' – considers an unpolarised light source and describes the angle at which only the polarised portions of this light perpendicular to the incident plane are reflected. According to this law, if unpolarised light falls onto the surface at the right angle, it will be reflected back from the surface as a beam of linearly polarised light.

### ■ **Irradiance**

This describes the sum total of electromagnetic energy or optical radiation energy that falls as light onto the surface. The value is given in watts per square metre. From this particular perspective, the sensitivity of the human eye is not considered at all.

### ■ **Jitter**

The term jitter refers to a periodic variation in a digital signal or the transmission of such signals from a true, reference periodicity. This jitter causes inaccuracies in the transmission of the signal.

### ■ **Lambertian scatterer**

A Lambertian scatterer is an emitter for which the radiance over the entire light field is constant in all directions.





## **Contact**

iiM GmbH measurement + engineering  
Neuer Friedberg 5  
98527 Suhl, Germany

Phone: (+49) 3681 455 19-0  
Fax: (+49) 3681 455 19-11  
Web: [www.iiM-AG.com](http://www.iiM-AG.com)  
Email: [info@iiMAG.de](mailto:info@iiMAG.de)

**[www.lumimax.com](http://www.lumimax.com)**